

peterson

STROBE TUNERS

The Sound of Precision.

VS-R StrobeRack™ User Manual



SR-EX StrobeRack Expander™ Module

Strobe
RACK™ VS-R™

CONTENTS

Safety Instructions	4
Introduction	5
Using Your New StrobeRack™	5
Front Panel Features	7
Rear Panel Features	8
Rear Panel with SR-EX Expander Module	9
StrobeRack™ Rear Panel Features (With SR-EX™ Module Installed)	10
StrobeRack™ Front Panel Screens	11
StrobeRack™ Front Panel Controls	12
Menu Button	13
Cents Button	18
Preset Button	18
Sweetener Button	18
Drop Tuning Button	19
Save Button	19
Audio Tones	19
Peterson Sweeteners™	20
A Word About Peterson Sweeteners	21
A Word About Temperaments	22
Setting up Presets on the Peterson StrobeRack	23
Recalling Presets	24
Setting Guitar & Bass Intonation Using Your Peterson StrobeRack	25
User-Programmable Sweeteners	26
Rear Panel Lamp	26
Optional StrobeRack Accessories	26
Remote Control Options	26
StrobeRack SR-EX Pro Expander Module	27
Tips To Keep Your Instrument In Tune	28
StrobeRack™ Signal Routing	30
Frequently Asked Questions	40
Warranty & Specifications	41



IMPORTANT SAFETY INSTRUCTIONS

- READ, FOLLOW, HEED, AND KEEP ALL INSTRUCTIONS AND WARNINGS.
- DO NOT OPERATE NEAR ANY HEAT SOURCE AND DO NOT BLOCK ANY VENTILATION OPENINGS ON THIS APPARATUS.
- DO NOT USE THIS APPARATUS NEAR SPLASHING, FALLING, SPRAYING, OR STANDING LIQUIDS.
- CLEAN ONLY WITH A LINT-FREE, DAMP CLOTH AND DO NOT USE CLEANING AGENTS.
- ONLY CONNECT POWER CORD TO A POLARIZED, SAFETY-GROUNDED OUTLET WIRED TO CURRENT ELECTRICAL CODES.
- PROTECT THE POWER CORD FROM DAMAGE DUE TO BEING WALKED ON, PINCHED, OR STRAINED.
- UNPLUG THE APPARATUS DURING LIGHTNING STORMS OR WHEN UNUSED FOR LONG PERIODS OF TIME.
- ONLY USE ATTACHMENTS AND ACCESSORIES SPECIFIED BY THE MANUFACTURER FOR SAFE OPERATION AND TO AVOID INJURY.
- WARNING: TO REDUCE THE RISK OF ELECTRICAL SHOCK OR FIRE, DO NOT EXPOSE THIS UNIT TO RAIN OR MOISTURE.
- SERVICE MUST BE PERFORMED BY QUALIFIED PERSONNEL.

RISK OF ELECTRIC SHOCK.

DO NOT OPEN.

WARNING: TO REDUCE THE RISK OF FIRE OR ELECTRICAL SHOCK, DO NOT EXPOSE THIS APPARATUS TO RAIN OR MOISTURE.

TO REDUCE THE RISK OF ELECTRIC SHOCK, DO NOT REMOVE COVER. NO USER-SERVICEABLE PARTS INSIDE.

RIESGO DE CORRIENTAZO.

NO ABRA.

PRECAUCION: PARA REDUCIR EL RIESGO DE INCENDIOS O DESCARGAS ELECTRICAS, NO PERMITA QUE ESTE APARATO QUEDE EXPUESTO A LA LLUVIA O LA HUMEDAD. PARA DISMINUIR EL RIESGO DE CORRIENTAZO, NO ABRA LA CUBIERTA. NO HAY PIEZAS ADENTRO QUE EL USARIO PUEDA REPARAR DEJE TODO MANTENIMIENTO A LOS TECHNICOS CALIFICADOS.

RISQUE D'ELECTROCUTION.

NE PAS OUVRIR.

ATTENTION: PROTÉGEZ CET APPAREIL DE LA PLUIE ET DE L'HUMIDITÉ. AFIN D'ÉVITER TOUT RISQUE D'INCENDIE OU D'ÉLECTROCUTION. POUR RÉDUIRE D'ELECTROCUTION NE PAS ENLEVER LE COUVERCLE. AUCUNE PIÈCE INTERNE N'EST REPRABLE PAR L'UTILISATEUR. POUR TOUTE RÉPARATION, S'ADRESSER À UN TECHNICIEN QUALIFIÉ.

Note: This equipment has been tested and found to comply with the limits for a Class B digital device, pursuant to part 15 of the FCC Rules. These limits are designed to provide reasonable protection against harmful interference in a residential installation. This equipment generates, uses and can radiate radio frequency energy and, if not installed and used in accordance with the instructions, may cause harmful interference to radio communications. However, there is no guarantee that interference will not occur in a particular installation. If this equipment does cause harmful interference to radio or television reception, which can be determined by turning the equipment off and on, the user is encouraged to try to correct the interference by one or more of the following measures:

- Reorient or relocate the receiving antenna.
- Increase the separation between the equipment and receiver.
- Connect the equipment into an outlet on a circuit different from that to which the receiver is connected.
- Consult the dealer or an experienced radio/TV technician for help.

Unauthorized changes or modifications to this system can void the user's authority to operate this equipment.

Introduction

The Peterson **StroboRack™ VS-R** is a unique rack mount tuner with an unequalled real-time display and accuracy of 0.1 cent using Peterson's exclusive Virtual Strobe™ Technology. It has a full complement of exclusive *Sweetened Tunings™* for guitar, bass, steel guitar and Dobro® and a wide range of classical temperaments for other instruments. It is also a programmable tuner, allowing you to program up to eight of your own tempered tunings as well as giving you access to 33 other preset temperaments and *Sweeteners™*. The StroboRack is the first tuner to offer inputs for instruments with mono, stereo and balanced signals (with optional SR-EX module installed).

We strongly advise you to read this manual thoroughly to get the most out of your new StroboRack.

Using Your New Peterson StroboRack™

The StroboRack accepts any voltage between 95 and 250VAC automatically; no adjustment is needed for operation with most global voltage standards. Simply use a power cable with the correct power plug for your country or location.

Basic Operation

Using the included power cable, connect your StroboRack to a grounded A/C power outlet.

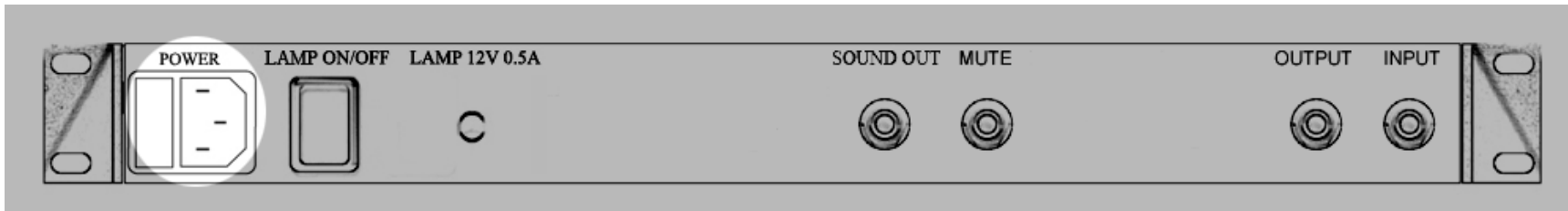

Connect a ¼" patch cord between the output jack of the StroboRack and the input jack of your amp or FX unit

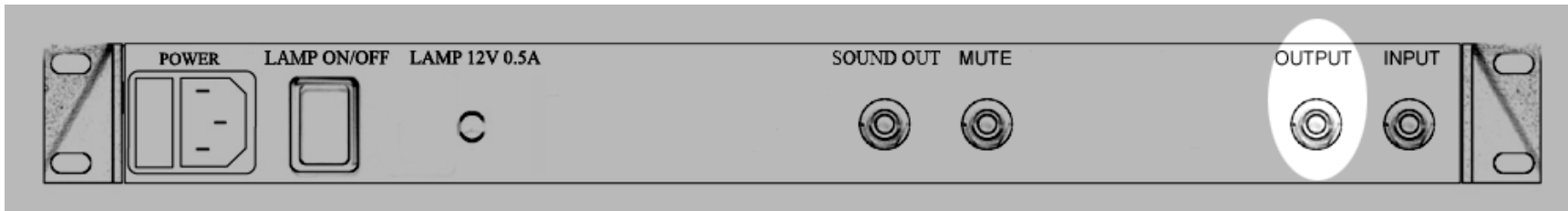

Using a ¼" cord connect your instrument to the front input

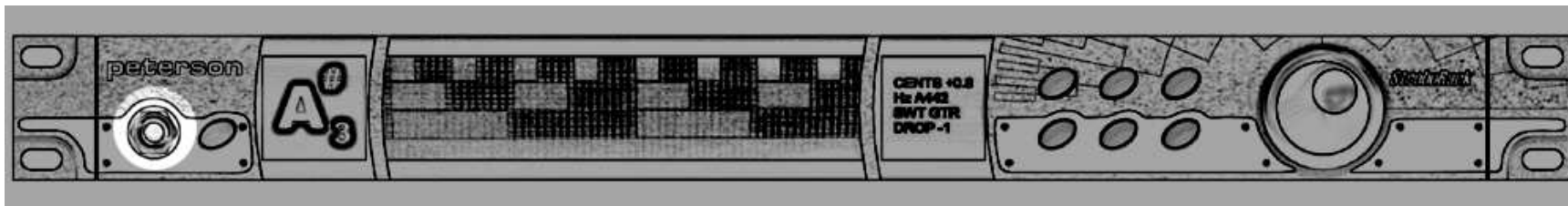

...or rear input of the StroboRack. The front input overrides the rear input.

Remember to first activate the mute function to avoid possible noise while plugging in your instrument.

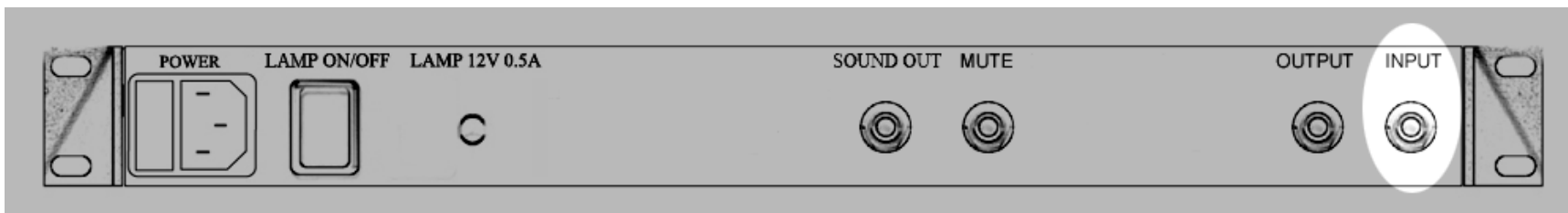

Switch on the unit using the power switch located beside the A/C receptacle on the rear panel.

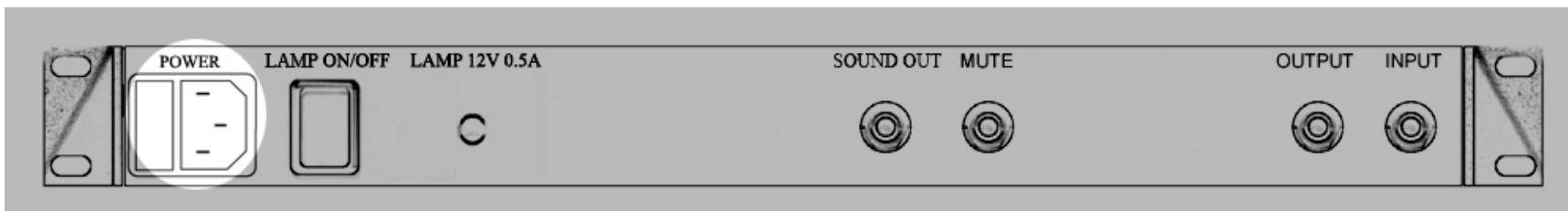

Play a note on your instrument, then observe the note displayed on the note screen.

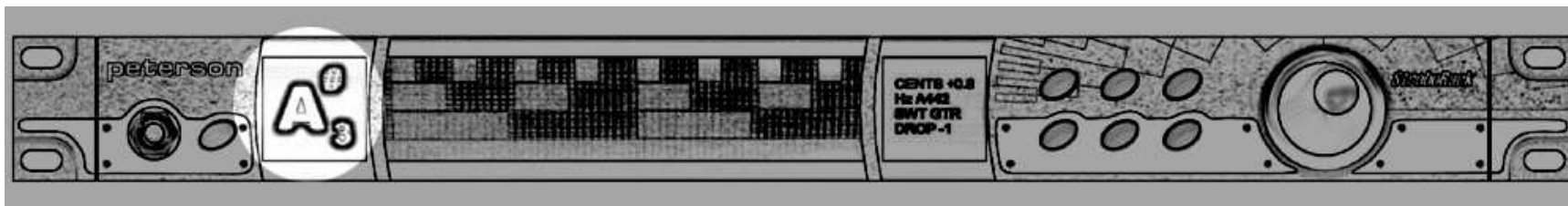

After noting the note name and octave, observe the Virtual Strobe™ screen.

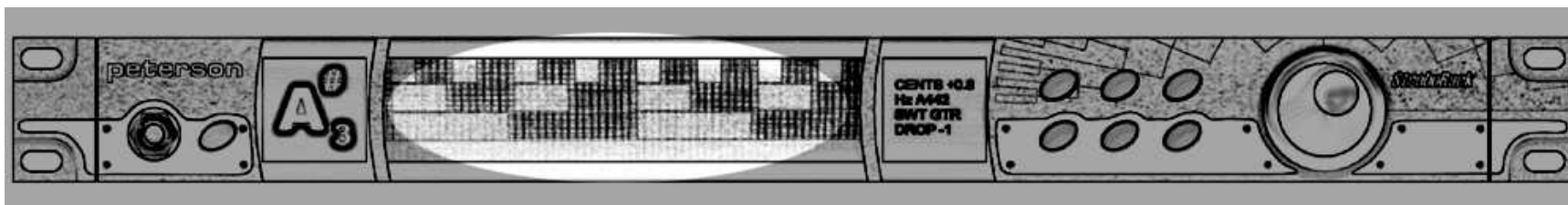

A movement of the image to the left indicates that the instrument's note is flat; a movement to the right indicates that the note is sharp. When the strobe image hovers or becomes immobile, the note is in tune to within 0.1 cent.

Strobe Newbie?

If you're new to strobe tuners, you will notice that they are much more sensitive and accurate than your previous tuner. This may mean that initially you'll need to adjust your "touch" when you pluck a string to tune.

Instead of a plectrum, use your finger or thumb to gently pluck the string.

You can also use this short cut – simply reduce the volume of your instrument, until you become accustomed to tuning accurately.

The StrobeRack's™ superior accuracy makes it the ideal intonation tool; use it to regulate your instrument's intonation to your own personal taste.

StroboRack™ Front Panel in Depth

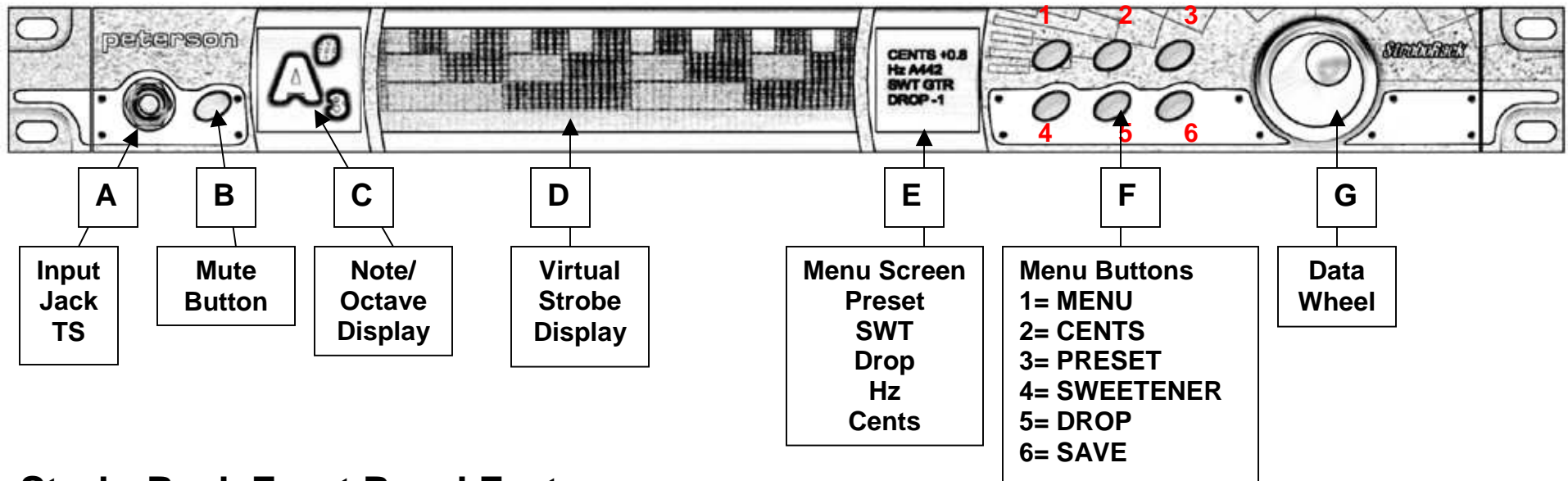

StroboRack Front Panel Features:

- A. Input Jack – ¼” metal chassis-mounted jack. When engaged, overrides rear combo jack input.
- B. Mute Button - backlit when pressed; mutes all active outputs, inactive if footswitch is engaged (LED will indicate status in either case).
- C. Note Display - constantly on; displays note octave and sharp/flat sign.
- D. Strobe Display - constantly on or only on when tuning; selectable in menu.
- E. Menu Screen - constantly on; displays current settings.
- F. Menu Buttons - backlit when pressed; gives the Data Wheel control over its parameter's value.
- G. Data Wheel - rotation changes the value of the backlit menu button's parameter, pressing selects the value.

StroboRack™ Rear Panel Features

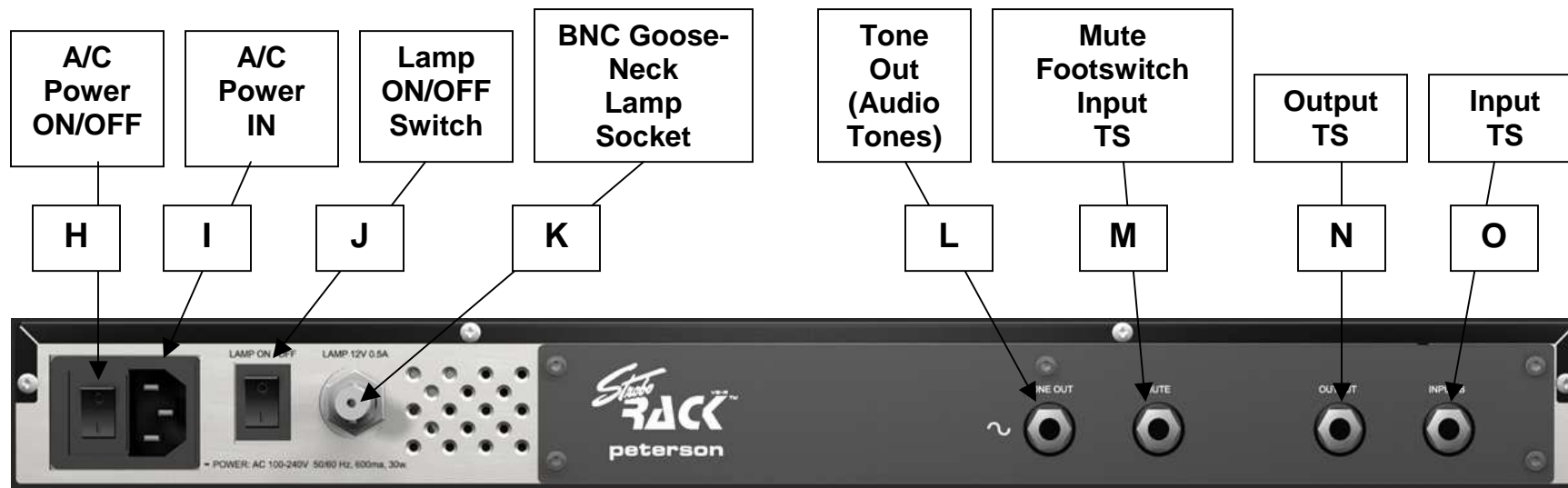

- H. A/C Power Switch – rocker type switch.
- I. Screw-In A/C Power Fuse Receptacle - chassis-mounted.
- J. Lamp Power On/Off Rocker Switch - chassis-mounted.
- K. BNC Power Socket 12V - chassis-mounted for gooseneck light.
- L. Mono Output - ¼" chassis mounted metal jack on rear panel of StroboRack for audio reference tone output.
- M. ¼" TS* Socket - mutes with single TS* footswitch.
- N. Mono Output - ¼" chassis mounted metal jack on rear panel of StroboRack. This is the audio output jack.
- O. Mono Input Jack – ¼" metal chassis-mounted jack. Active unless input A is engaged, overrides this jack input.

StroboRack™ Rear Panel (With SR-EX™ PRO Expander Module Installed)

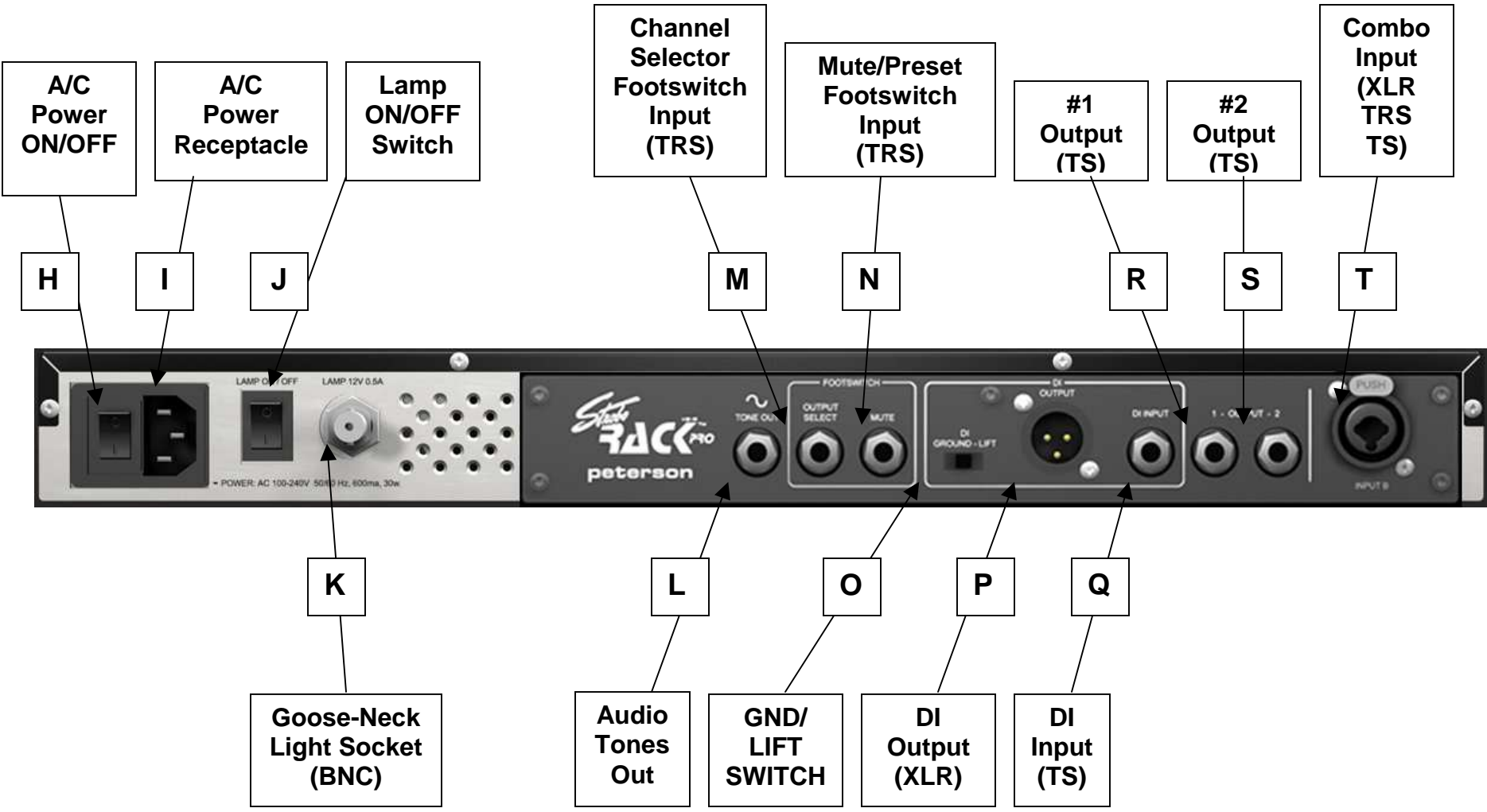

StroboRack™ Rear Panel Features (With SR-EX PRO Expander Module Installed)

- H. A/C ON/OFF Power Switch – rocker.
- I. A/C Power Receptacle - chassis-mounted.
- J. Lamp Power On/Off Rocker Switch - chassis-mounted.
- K. BNC Power Socket 12V - chassis-mounted for gooseneck lamp.
- L. Audio Tones Output - ¼” chassis mounted metal jack on rear panel of StroboRack for audio reference tone output.
- M. ¼” TRS** Socket - AA/BB channel select with TRS dual latching footswitch stereo Input ¼” chassis mounted metal jack socket on rear panel of StroboRack. This is an input for a dual stomp switch which is routed as follows: Tip=Output #1, Ring = Output #2, Sleeve = Ground.
- N. ¼” TRS** Socket - mute with single TS* latching footswitch, or mute/preset switch with TRS latching dual footswitch stereo input ¼” chassis mounted metal jack socket on rear panel of StroboRack. This is an input for a single or dual footswitch which is routed as follows: Tip=Mute, Ring = Preset Change, Sleeve = Ground.
- O. Three Position Slider Switch - position 1 = DI GND, position 2 = Auto GND Detect, position 3 = DI GND LIFT.
- P. Male XLR*** Socket – DI/ balanced signal output. This output accepts signal from inputs **A** & **T**, except when DI input jack **Q** is engaged, in which case the signal from **Q** takes precedence.
- Q. Mono Input - ¼” chassis mounted metal jack on rear panel of StroboRack. This jack is linked directly to the DI output **P**, and enables the user to connect one of the outputs with the DI using a patch cord or use the DI for another instrument besides the one being tuned by StroboRack.
- R. Mono Output - ¼” chassis mounted metal jack on rear panel of StroboRack. This is the main audio output jack. Both this output and output **S** are wired respectively to tip & sleeve of combo input **T**, in order to facilitate stereo in/out operation. If mono input **A** is engaged, combo input **T** is overridden/ disengaged and input **A** tip feeds signal to **R** output only, output **S** is muted.
- S. Mono Output - ¼” chassis mounted metal jack on rear panel of StroboRack connected to ring of combo input **T**. This output jack is a second output to feed a second amp or can be patched to DI input jack **R**, and can also be selectable using a footswitch. If **M** engages with a dual TRS footswitch, one or both outputs can be selected (**R** or **S** or both).
- T. Combo input female XLR, TRS & TS jack - chassis mounted with two Philips screws on rear panel of StroboRack. This jack will function only if front panel input **A** is not engaged. This input accepts a regular mono signal, a stereo signal or a balanced signal.

*TS = ¼” Tip-Sleeve - Tip carries signal and Sleeve is ground.

**TRS = ¼” Tip-Ring-Sleeve - Tip and Ring carry two mutually independent signals and Sleeve is common ground.

***XLR = Three Pin Balanced - pin 1 = ground, pin 2 = + and pin 3 = - .

StroboRack™ Front Panel Screens

There are three screens on the front panel:

1. Note Screen

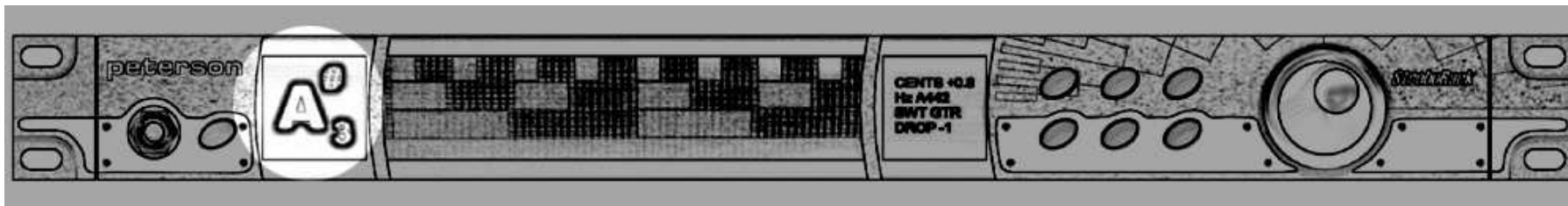

This screen displays the note currently being tuned/ tracked by the tuner and its octave represented by a number. Please note that if nothing is plugged into the input jacks, the StroboRack's built-in mic is automatically enabled and will pick up whatever sounds are in the vicinity.

2. Strobe Screen

This screen displays the stroboscopic tuning image.

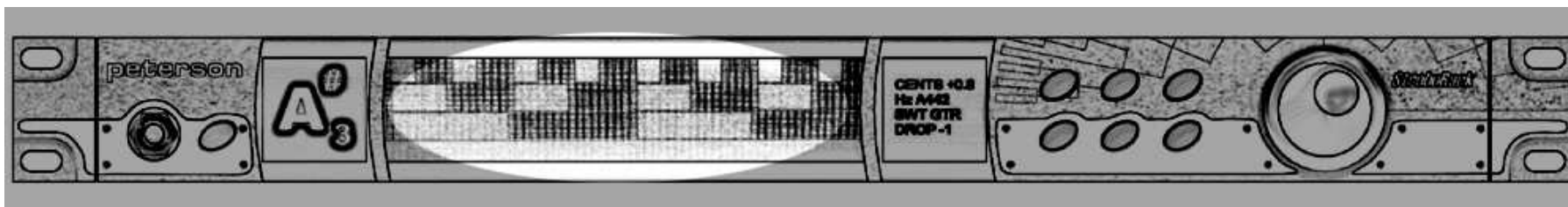

If the image moves to the left, the note being tuned is flat; if it moves to the right, the note is sharp. To get the note in tune, make adjustments to the tuning mechanism of the instrument to be tuned until the strobe image is hovering or completely immobile.

3. Info Screen

This screen displays the settings that are currently active in the tuner

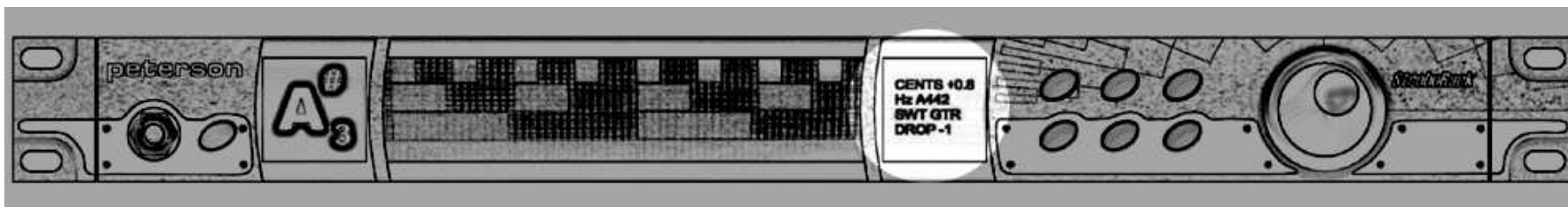

These settings include concert pitch, drop tuning, Sweetener™ / temperament, cents and preset.

StroboRack™ Front Panel Controls

There are seven buttons on the front panel of the StroboRack. One is on the left, which mutes the tuner's output(s).

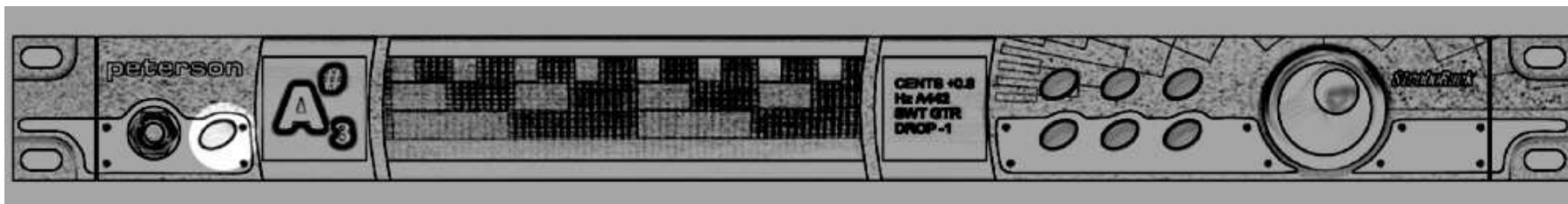

The adjacent blue LED indicates the status of the mute function. When this LED is lit, the tuner's output(s) are muted for silent tuning; when the LED is off, the outputs are un-muted and the instrument signal passes through the tuner unhindered.

Connecting an optional mute pedal to the rear mute pedal jack socket disables the front panel mute button, but the status LED operates in either case.

On the right hand side of the StroboRack, six buttons and a data wheel offer complete control over the tuner's operation and programming features.

After pressing one of the buttons,

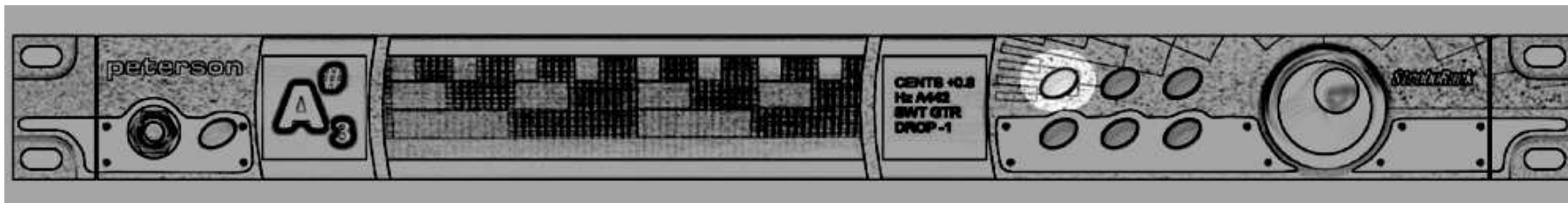

- the parameters on the info screen can be highlighted by rotating ...

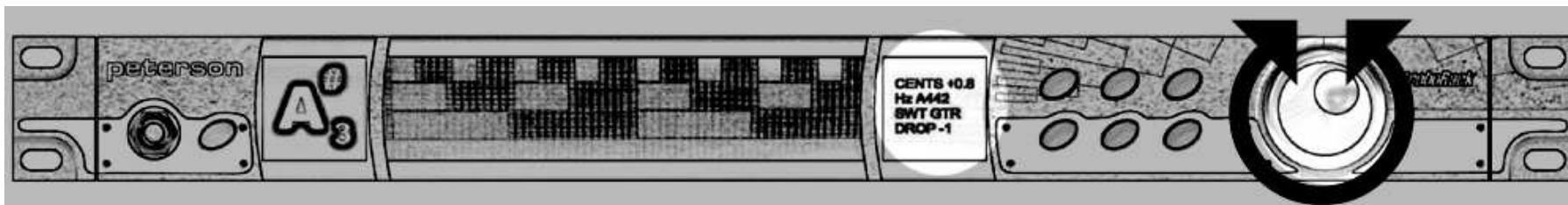

- or edited by gently pressing the data wheel. Holding the Data wheel down for 2 seconds returns the currently selected parameter (Drop, SWT, cents, A4) back to default.

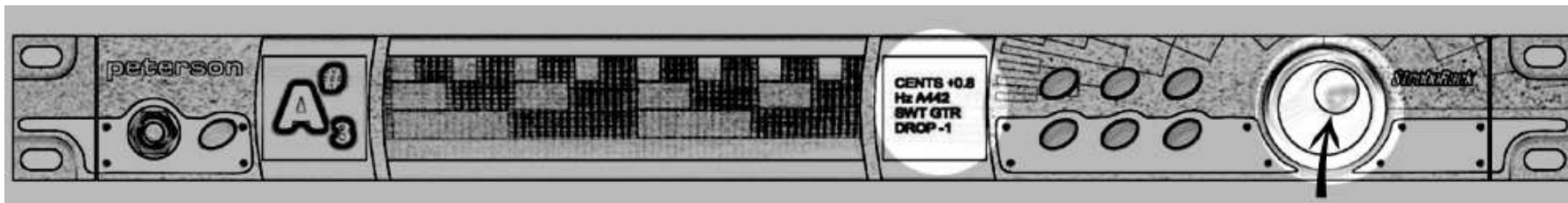

MENU BUTTON

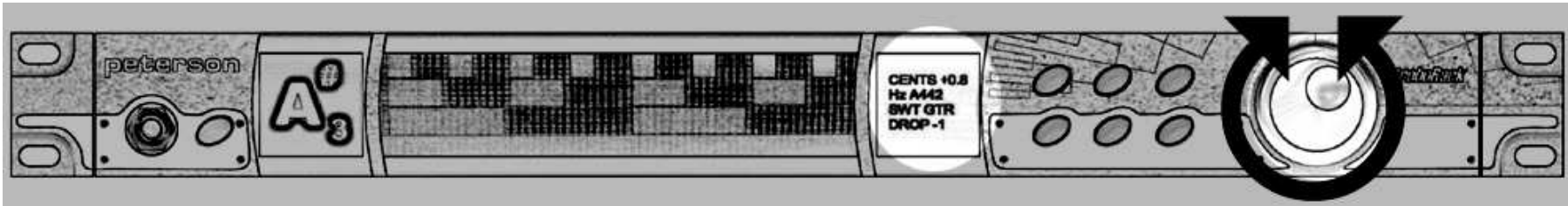

When pressed, a list of parameters appears. Rotating the data wheel can individually highlight each one.



The parameters under the MENU button include:

AUTO – Controls whether the tuner or the user selects notes to be tuned (*AUTO*matically or *MAN*ually). *AUTO* is the default.

1. Highlight the parameter by rotating data wheel ;
2. Select by pressing the data wheel ;
3. Edit to Manual operation by once again rotating the data wheel.



A440.0 – Controls the concert pitch in 0.5Hz increments. The adjustment range is 390.0Hz to 490.0Hz. The default value is 440.0Hz.

1. Highlight the parameter by rotating the data wheel ;
2. Select by *pressing* data wheel ;
3. Edit the concert pitch by once again *rotating* the data wheel .



Press the **SAVE** button if you wish to save the new value to memory.

PROG SWT – Allows the programming of user-defined Sweeteners.

1. Highlight the parameter by rotating the data wheel;
2. Select by pressing data wheel and rotate wheel to select the desired patch;
3. Press the data wheel to start programming the first note and rotate the wheel to adjust its cent value;

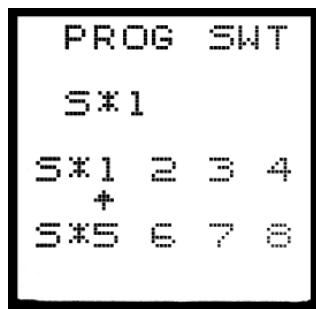

4. Press the data wheel to start programming the next note and rotate the wheel to adjust its cent value;
5. Continue through the entire scale until all required notes have new cent values.
6. Program each E in EADGBE separately. E↑ means high E.



7. When all notes are programmed press the SAVE button to save to the StroboRack's memory OR;
8. Give the Sweetener™ a custom name. *Rotate* the data wheel to scroll through letters and numbers. When the desired character is displayed, *press* the wheel to advance to the next space: 8 spaces are available. When naming is complete, press the SAVE button.

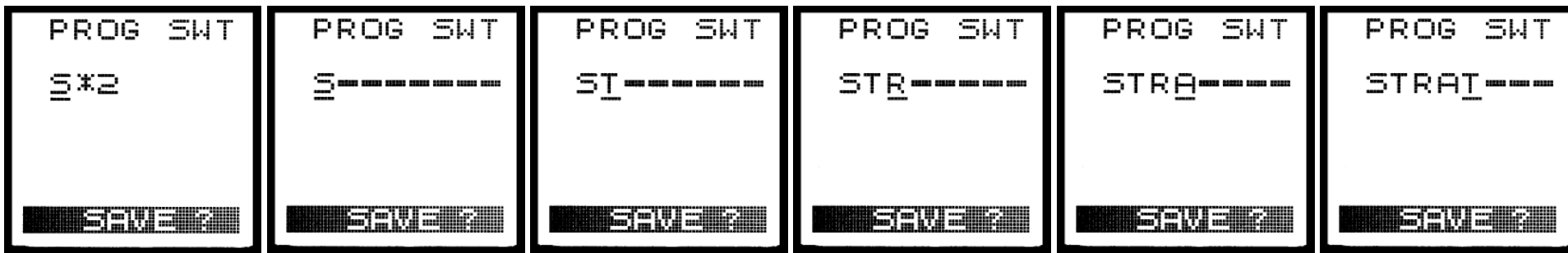

CLR SWTS – Allows the deleting of user-defined Sweeteners, the cent value of all 8 programmable Sweeteners will return to zero and any custom names will be returned to factory default names (Note: factory presets cannot be deleted).

Use the Data Wheel to highlight CLR SWTS, then press the Data Wheel to select it. Press the Data Wheel again to confirm that you wish to delete or clear all programmable Sweeteners.



SCRN SVR. - Controls the StrobeRack's built-in Screen-Saver/ Marquee that appears when the tuner is bypassed.

Preset static, scrolling and flashing marquees are selectable as well as the ability to create a custom user marquee to display a band name, a website or a song. An immobile logo can be used to avoid distracting an audience whereas a scrolling or flashing message can call their attention to the name of the band, the next gig, a nickname etc. This is a unique feature among rack equipment and means that the StrobeRack is always performing a useful function as a "digital billboard" even when the owner is not using it or indeed even present on stage. Below are examples of a scrolling message and a flashing message.



The factory default is to have no message, the signal is tracked whether muted or unmuted. If the tuner is connected to an instrument, but receives no signal, it will automatically display the static StrobeRack logo. This disappears again in favor of the moving strobe image when signal is received again.

CHOOSING A PRESET MESSAGE FOR THE MARQUEE/SCREEN SAVER

1. Rotate the data wheel to highlight the parameter.
2. Press the wheel to view choices. The first is the strobe image. Selecting this means the image will track whether the tuner is muted or not. "STROBO" causes an immobile StrobeRack logo to appear when the tuner is bypassed. "PRE NAME" causes the current preset name to appear. "CUSTOM" causes whatever message the owner has programmed to appear. Rotate the data wheel to highlight the desired image, then press to choose.



The scroll/flash screen then appears. Rotate the wheel to choose between scrolling and flashing and press the SAVE button to save your choice to memory.

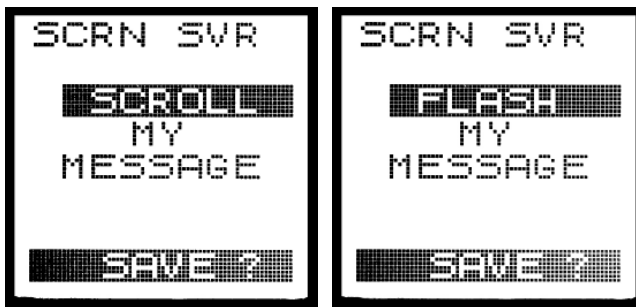

To view the result, ensure that the StrobeRack™ is unmuted (in bypass mode).

PROGRAMMING A CUSTOM MESSAGE FOR THE MARQUEE

After pressing the MENU button, rotate the data wheel clockwise to highlight "SCRN SVR" and press the wheel to reveal the SCRN SVR page. Rotate the wheel to highlight "CUSTOM" and press the wheel to select it. The default factory setting "STROBE TUNING BY PETERSON" appears.

Now, as described in the section about naming Sweeteners™, rotate the wheel to select letters, numbers or spaces and press it to advance to the next letter/number/space. Use the "□" character when you want the space after your message to truncate and loop back to the start immediately. When finished, press the SAVE button. To activate the new message see **CHOOSING A PRESET MESSAGE FOR THE MARQUEE** above.



CENTS BUTTON

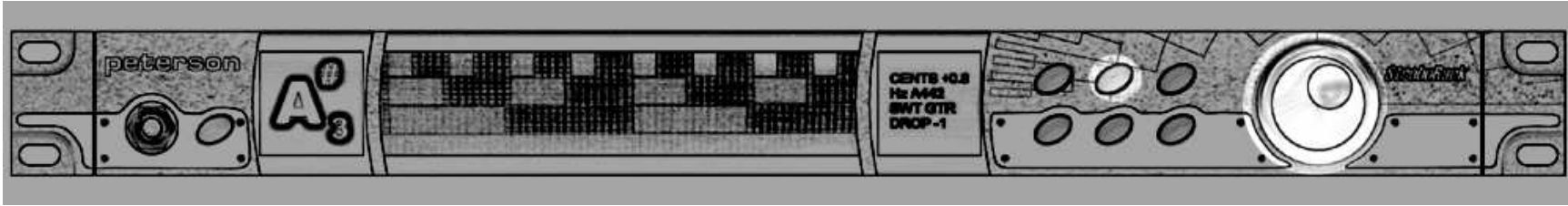

When this button is pressed, the cent value is highlighted (default is 00.0 cents).

Use the data wheel to enter a plus value (clockwise), or a minus value. This value is active only as long as the tuner is switched on. This feature may be used to quickly (temporarily) align the StrobeRack™ to an out-of-tune piano in order to allow subsequent tuning of other instruments to match. It can also be used to measure an existing tuning or temperament whose values are unknown by playing each note and adjusting the cent control to steady the image. The resulting cent offset is displayed to 0.1 cent resolution on the menu screen. When measuring a tuning, ensure that the tuner is set to EQU, otherwise the measurement will not be useable.

This control can also be used to quickly (temporarily) align the StrobeRack to a recording that is slightly out of tune with standard pitch. Reasons for this are varied, from altered tape/ playback speeds to instruments which, at the time of recording, were in-tune internally but differ from standard pitch.

PRESET BUTTON

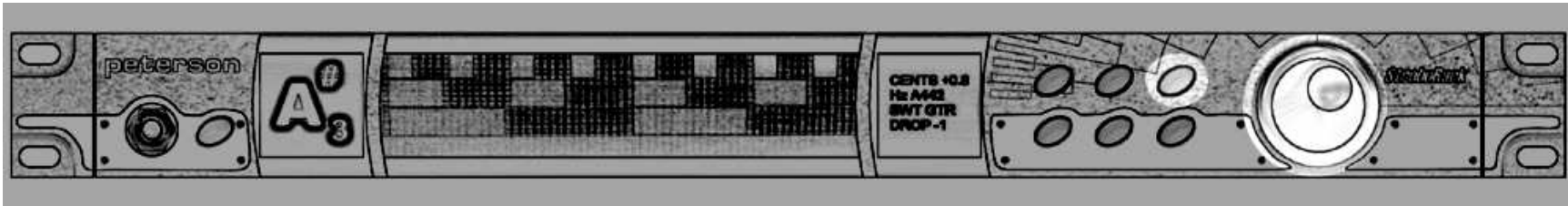

This button controls which preset is active at any one time. A *StrobeRack Preset* is a combination of a Sweetener (SWT) and a DROP value which can be programmed in any sequence by the user and quickly changed by rotating the data wheel or remotely using a footswitch*.

*With SR_EX Expander installed only. Footswitch is available as an accessory from www.peterson tuners.com/store

SWEETENER™ BUTTON

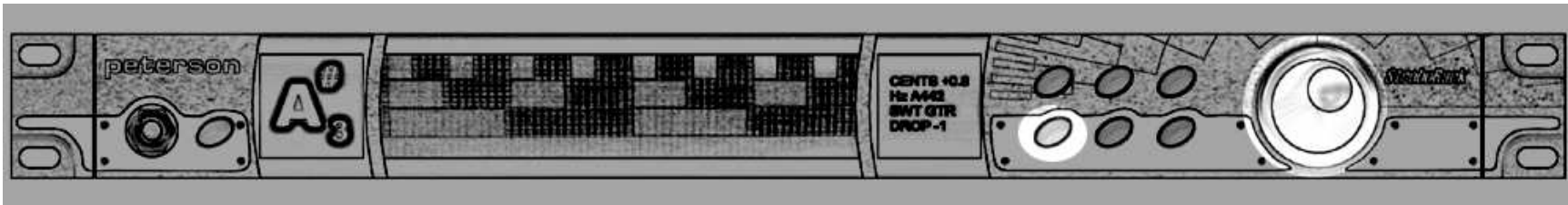

This allows the user to choose a Sweetener (see pages 10 & 11).
Using the data wheel (G), the individual Sweeteners can be selected.

DROP TUNING BUTTON

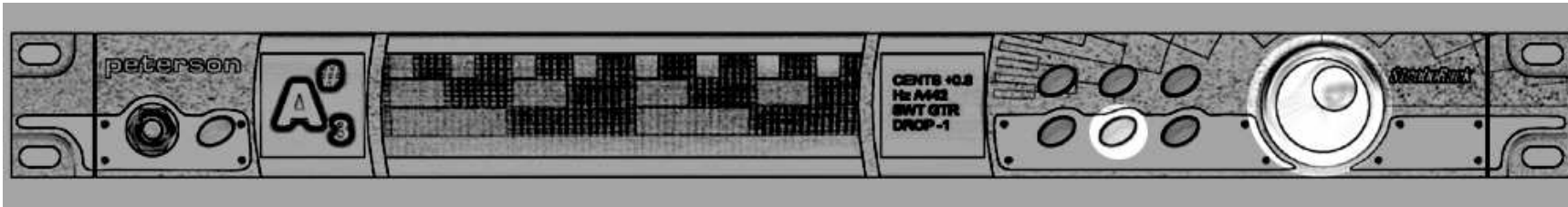

This allows the user to drop-tune the present tuning to anywhere. Use the data wheel to enter the drop tune value; -1 means one half-step (semitone) down, -2 means two half-steps down etc.

SAVE BUTTON

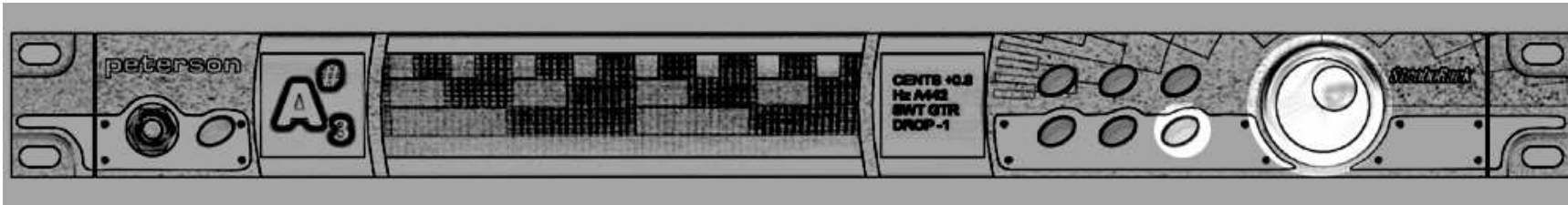

The SAVE button gives the user access to the SAVE page. The data wheel allows the active parameters to be saved, deleted, replaced, added, or no action taken (Quit).

AUDIO TONES

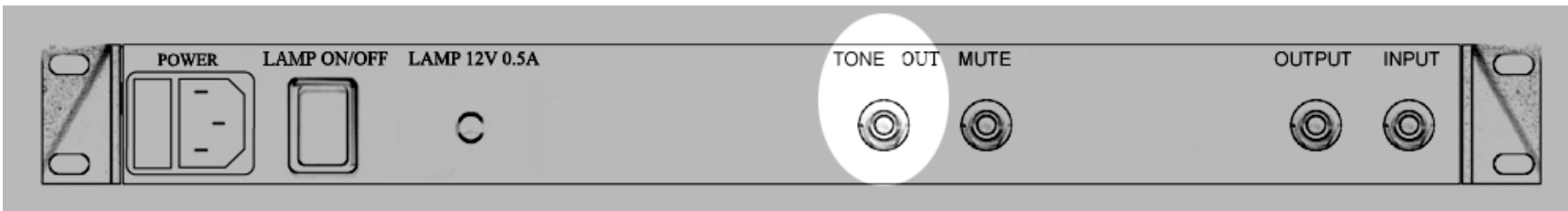

Audio reference signals are available from the Sound Out jack on the rear panel of the StrobeRack™. Plugging a cord with a ¼ inch (6.3mm) jack into the socket activates the tone, which can then be plugged into any amplifier via the other end of the cord. Set the Auto/Man control to MAN and scroll through the notes using the data wheel. Always set the amplifier's volume to zero before plugging in. This signal can also be used to calibrate a software tuner like Peterson StrobeSoft™, thus eliminating computer sound card errors.

Peterson Sweeteners™

NAME	SWEETENERS	NAME	HISTORIC TEMPERAMENTS
01 EQU	Equal Temperament	JMA	Just Intonation - Major
02 GTR	Sweetened Guitar	JMI	Just Intonation - Minor
03 ACU	Acoustic Guitar	4MT	Quarter Comma Meantone
04 DAD	Sweetened DADGAD	6MT	Sixth Comma Meantone
05 G12↓	12 String (Standard Strings)	PYT	Pythagorean
06 G12↑	12 String (Octave Strings)	WRK	Werckmeister
07 BRT	Sweetened Baritone Guitar	KRN	Kirnberger
08 BAS	Sweetened Bass Guitar	KLN	Kellner
09 BFE	Buzz Feiten® Electric Guitar	YNG	Young
10 BFE ^{IN}	Buzz Feiten® Electric Guitar Intonation	VAL	Vallotti
11 BFB	Buzz Feiten® Bass Guitar	RAM	Rameau
12 BFB ^{IN}	Buzz Feiten® Bass Guitar Intonation		
13 BFA	Buzz Feiten® Acoustic Guitar		
14 BF12↓	Buzz Feiten® 12 String (Std. Strings)		
15 BF12↑	Buzz Feiten® 12 String (Octave Strings)		
16 SE9	E9 Tuning for Steel Guitar (Sharp Es)	NAME	PROGRAMMABLE SWEETENERS
17 SC6	C6 Tuning for Steel Guitar	S-1	User Programmable Temperament
18 OE9	E9 Tuning for Steel Guitar (E 0.0 cent)	S-2	User Programmable Temperament
19 U12	Tuning for Universal Steel Guitar	S-3	User Programmable Temperament
20 DBO	Perfect Thirds for Dobro®	S-4	User Programmable Temperament
21 DB♯	Half Tempered Thirds for Dobro®	S-5	User Programmable Temperament
22 VLN	Perfect Fifths for Violin	S-6	User Programmable Temperament
23 VLA	Perfect Fifths for Viola	S-7	User Programmable Temperament
24 CLO	Perfect Fifths for Cello	S-8	User Programmable Temperament

A Word About Peterson Sweeteners

A “Sweetener” is a group of *twelve or fewer* notes, which are precisely and individually adjusted in degrees of sharpness and flatness to sweeten the tuning of instruments using a Peterson tuner.

Many musicians are familiar with having to tweak their instrument’s tuning after using a digital tuner. Peterson’s Sweeteners make this unnecessary.

The Sweetener’s names are simply a guide; for example, the Dobro® settings can be used for tuning any guitar to open A, D or G.

Sweeteners are available only in Peterson Tuners.

EQU	Unsweetened
GTR (GTR™)	Peterson guitar Sweetener, which makes 4 th & 5 th intervals (as well as the G to B third) more consonant.
ACOUST (ACU™)	Peterson acoustic guitar Sweetener, a unique stretch tuning which compensates for capo application.
DADGAD (DAD™)	Peterson Sweetened Tuning for guitars tuned to DADGAD.
G12↓ (G12↓ STD™)	Peterson Sweetened Tuning for the 6 standard strings of 12-string guitars.
G12 (G12↑ OCT™)	Peterson Sweetened Tuning for the 6 octave strings of 12-string guitars.
BARITONE (BRT™)	Peterson Sweetened Tuning for Baritone guitars.
Bass (BAS™)	Peterson bass guitar-specific Sweetener for use when playing with piano.
B^F-Elec (B^FE)	Special tuning for electric guitars featuring the Buzz Feiten Tuning System®*.
B^F-Elec^{IN} (B^FE^{IN})	Intonation offsets for electric guitars featuring the Buzz Feiten Tuning System®.
B^F-Bass (B^FB)	Special tuning for bass guitars featuring the Buzz Feiten Tuning System®.
B^F-Bass^{IN} (B^FB^{IN})	Intonation offsets for bass guitars featuring the Buzz Feiten Tuning System®.
B^F-Acoustic (B^FA)	Special tuning for acoustic guitars featuring the Buzz Feiten Tuning System®.
B^F-12↓STD (B^F12↓)	Special tuning for the 6 standard strings of 12-string guitars using the Buzz Feiten Tuning System®.
B^F-12↑OCT (B^F-12↑)	Tempered tuning for the 6 octave strings of 12-string guitars using the Buzz Feiten Tuning System®.
PSG-SE9 (SE9)	Sweetened tuning derived from the Jeff Newman system for steel guitar tuned to E9. E’s are 9.8 cents sharp.
PSG-SC6 (SC6)	Sweetened tuning derived from the Jeff Newman system for steel guitar tuned to C6.
PSG-OE9 (OE9)	Sweetened tuning derived from the Jeff Newman system for steel guitar tuned to E9. E’s are at 0.0 cents.
PSG-U12 (U12)	Universal Tuning for 12 String Pedal Steel (E9/B6).
DOBRO®**(DB^O™)	Sweetened Dobro ^R Tuning (Pure 3rds for Open A, D or G tunings) - Tune in playing position.
DOBR^R®(DB^R™)	Sweetened Dobro ^R Tuning (Half Tempered 3rds for Open A, D or G tunings) – Tune in playing position.
VIOLIN (VLN™)	(C)GDAE in perfect 5 th intervals for violin tuning (4 & 5 string violins). Tuning should be done by bowing.
VIOLA (VLA™)	CGDA in perfect 5 th intervals for viola tuning. Please note: Tuning should be done with a bow.
CELLO (CLO™)	CDGA perfect 5 th intervals for cello tuning. Please note: Tuning should be done with a bow.

A Word About Temperaments

Musical temperaments are systems used to determine where each note in the octave (12 notes) is to be placed in relation to the others. The most commonly used temperament in modern music is the *Equal Temperament*, in which the “space” or *interval* between each note and its immediate neighbor is always 100.0 cents. However, there are many other methods used to divide the octave. These temperaments are called Unequal. Press the Temp button and use the data wheel to scroll through the different temperaments:

Equal (EQU): All semitone intervals are exactly 100.0 cents wide.

Just Major (JMA): Just intonation is possibly the oldest known way of dividing the octave. The Just Major version features beatless major thirds, used to tune brass & woodwind ensembles.

Just Intonation is often called “Natural” tuning, because of its consonant intervals. It is usually used by brass players to enhance the sound of ensemble playing. Elements of this are also used in choral intonation.

Just Minor (JMI): Beatless minor thirds, see above.

Quarter (¼) Comma Meantone* (4MT): Meantone temperament, used for harpsichord.

One Sixth (1/6th) Comma Meantone* (6MT): Meantone temperament used for early music instruments such as lute, viol, viola da gamba etc.

Pythagorean (PYT): Beatless fifths, introduced by Greek mathematician Pythagoras (569 – 475 BC).

Werckmeister III* (WRK): Introduced by German organist Andreas Werckmeister (1645 - 1706), for tuning organ and harpsichord. Flexible tuning by which some distant keys are playable. Each key retains a particular color.

Kirnberger III* (KRN): Composer, theoretician and student of Bach, Johann Philipp Kirnberger (1721-1783) conceived the Kirnberger temperament. It is often referred to as the simplest of temperaments, having no pure thirds except the C-E interval, thus lending itself to music written in C Major. Avoid pieces in B, F# or Db which were rare at the time of inception. For tuning organ and harpsichord.

Kellner (KLN): The original “*wohltemperirte Clavier*” (*well tempered*) tuning introduced by Bach in the early 1700s and rediscovered by Professor Herbert Anton Kellner in the 1970s. The well-tempered fifths are almost all equal, being reduced by 1/5 of a Pythagorean comma (4.7 cents).

Young* (YNG): Thomas Young (1773 – 1829) introduced the original RGB theory of color. Following that, he applied similar thought to musical temperament. C & F are stable and there are some particularly smooth sounding 3rds, 4ths and 5th scattered among the keys. Used widely in forte piano tuning and harpsichord.

Vallotti* (VAL): Francesco Antonio Vallotti’s (1697-1780) well temperament for harpsichord is very close to Equal temperament. It is one of the mildest of the classic well temperaments.

Rameau* (RAM): This late French Baroque temperament by Jean-Philippe Rameau (1683 - 1764) is also known as “*Temperament Ordinaire*” and contains three beatless major thirds.

**Temperaments marked with an asterisk are often tuned using a Concert A setting of A=415Hz or A=392Hz depending on the period the music to be played was written in.*

****Buzz Feiten Tuning System is a registered trademark of Buzz Feiten Design and has no affiliation with Peterson Electro-Musical Products, Inc.**

***** Dobro is a registered trademark of the Gibson Guitar Corp. and has no affiliation with Peterson Electro-Musical Products, Inc.**

Setting up Presets on the Peterson StrobeRack™

In the StrobeRack, a preset is a combination of a choice of Sweetener and Dropped tuning value. It's possible to create a list of these presets which can be named and recalled by hand or with the remote footswitch* in any sequence.

When a preset is activated, its name flashes briefly on the large center strobe display before reverting to the strobe image and tuning can commence.

To program a preset:

1. Press the Sweetener button and select the desired Sweetener. This can be one of the Peterson Sweeteners or a user-defined Sweetener setting.

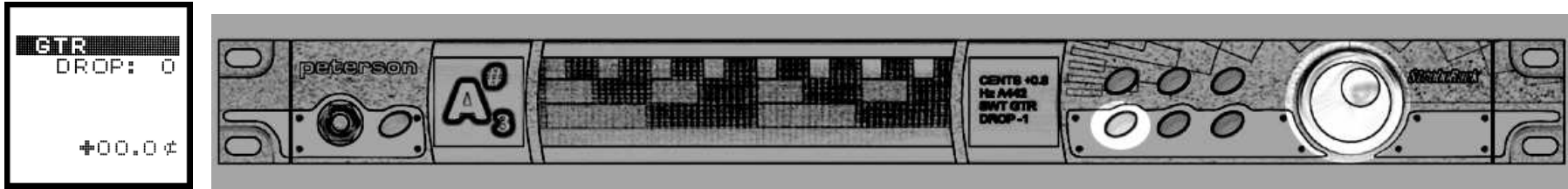

2. Press the Drop button and Select the desired Drop Tuning setting (if required).

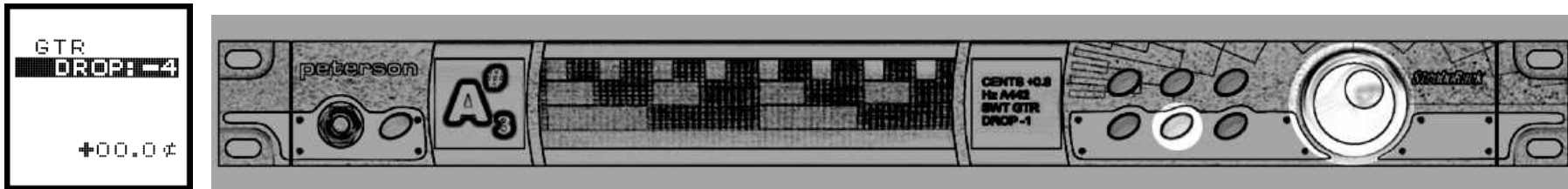

3. Press the Save button.

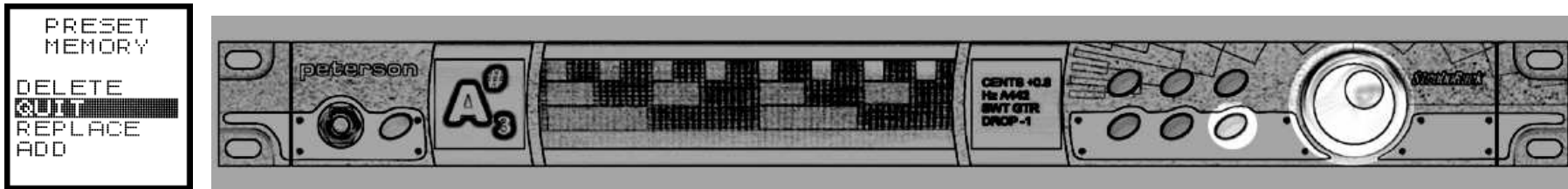

4. The Preset window appears showing the choices Delete (applies to last selected Preset), QUIT (to end the process without saving the preset), REPLACE (applies to last selected Preset) and ADD to add the new preset to the list of existing ones.
5. Rotate the data wheel to highlight ADD.

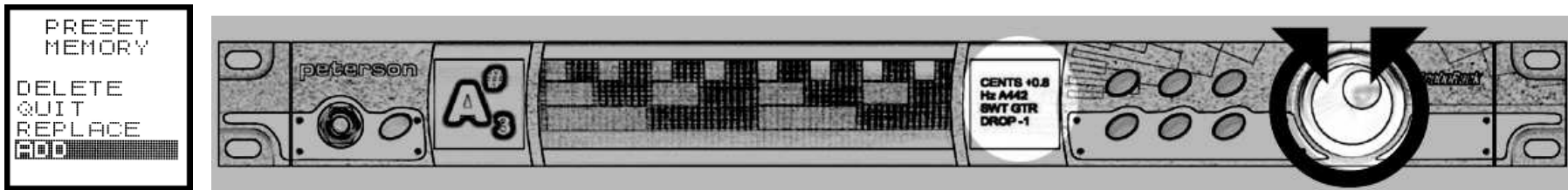

6. Press the data wheel to proceed to the renaming page.
7. Rotate the data wheel to name the preset (if not required, skip this step and proceed to step 8)



8. Press the Save button to save the preset and name.

*With optional SR-EX Expander only

Recalling Presets

Press the Preset button and use the data wheel to scroll through the presets.

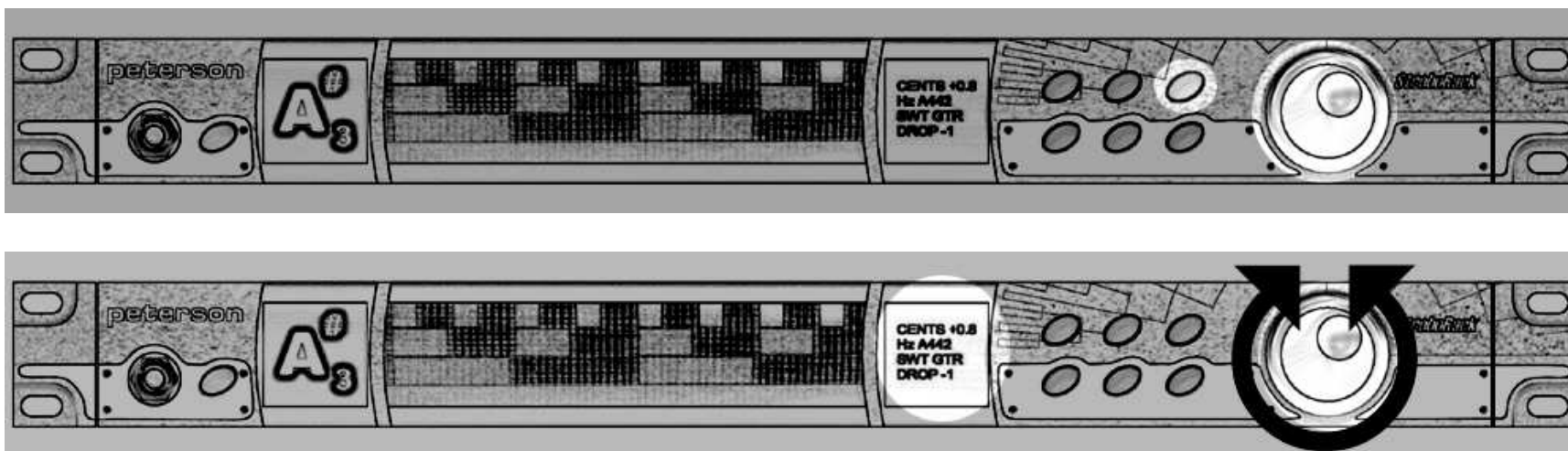

If the SR-EX Expander is installed, connect a dual latching footswitch to the rear panel socket marked MUTE/PRESET. Engaging the right hand footswitch (or whichever switch is connected to ring of plug) will advance the presets. When the footswitch is engaged, the name of the preset flashes briefly on the strobe screen before reverting back to the strobe image.

Setting Guitar & Bass Intonation Using Your Peterson StrobeRack™

After deciding on string gauge, setting string height (nut & bridge), neck relief, and all other factors that affect the guitar's intonation considerably, the individual string lengths need to be adjusted. For this task, use Equal temperament in the StrobeRack's SWT menu.

- Lower the pickups away from the strings to avoid "doubling" and electromagnetic pull.
- Lay the guitar flat on a bench to adjust it, but always check the intonation with the instrument in the playing position, as the readings will be visibly (and later audibly) different. You should always aim to freeze or "cage" the image on the strobe tuner display; the less movement the more accurate the results.

A common technique in setting the intonation is the 12th fret & flageolet comparison method. In this method, the flageolet or "harmonic" of the 12th fret is compared to the fretted string at the 12th fret, and saddle position is adjusted as follows:

- If the fretted note is *flat* compared to the flageolet note, move the bridge saddle *forward* to shorten the string.
- If the fretted note is *sharp* compared to the flageolet note, move the bridge saddle *back* to lengthen the string.
- Adjust until both fretted note and flageolet are identical in pitch.

While this is a common system, it is not always the most satisfactory.

One popular alternative is to adjust each string so that it is in tune at *two* points an octave apart from each other on the fret board using a strobe tuner. Using the 5th and 17th fret as an example:

- Tune a string at the 5th fret.
- Check the string at the 17th. If sharp, move the saddle back, thus lengthening the string. If flat, shorten the string by moving the saddle forward. Remember to fret the string using the pressure that you would normally apply while playing.
- Keep repeating this process until each string is in tune as much as possible at both the 5th and 17th frets.

This method takes time, and has to be repeated if you change string gauges, but if properly executed, it yields very satisfactory results.

Now, depending on your own taste, tune your guitar using one of the StrobeRack's many Sweeteners™. Find out how your instrument can *really* sound!

The methods described above are within anybody's reach. All you need are your ears and your [peterson](#) strobe tuner!

Please note that we have not referred to any method involving structural changes to the instrument. These are best discussed with a professional instrument technician.

User-Programmable Sweeteners™

There are eight user-programmable Sweetener settings in the StrobeRack™ (S-1 to S-8). The user can specify a Sweetener and program it into the StrobeRack for recall anytime.

Rear Panel Lamp



A BNC socket and ON/OFF switch allows the adding of an optional gooseneck lamp to the rear panel of the StrobeRack™. This lamp can be useful as a work light or as additional lighting to prevent accidents on dark stages. 12V LED, halogen and incandescent lamps are supported.

Optional StrobeRack Accessories

StrobeRack SR-EX PRO Expander Module

Mute Footswitch (Single footswitch) for use with *StrobeRack* or *StrobeRack SR-EX Expander™*

Mute/Preset Select Footswitch (Dual Footswitch) for use with *StrobeRack SR-EX Expander* only.

Channel Select Footswitch (Dual Footswitch) for use with *StrobeRack SR-EX Expander* only.

Gooseneck Lamp for use with *StrobeRack* or *StrobeRack SR-EX Expander*.

TP-2 Clip-on Tuner Pickup

Remote Control Options

StrobeRack VS-R™

Use a Peterson single latching footswitch (Part# 403086) inserted into the Mute jack on the

rear panel to remotely mute the StrobeRack's output signal for silent tuning.

Remote single latching footswitch (Part# 403086) is available from your Peterson dealer or from www.peterson tuners.com.



StroboRack™ SR-EX PRO Expander Module



INSTALLATION

Install the SR-EX PRO Expander according to the included instructions.

GENERAL

With the Expander installed, the StroboRack's input, routing and patching possibilities are vastly increased, but the operation of the tuner remains the same as do all front panel functions and procedures.

SIGNAL ROUTING

The rear panel combo (¼" Stereo/XLR) input recognizes automatically whether a ¼" mono, ¼" stereo or XLR type plug is inserted and routes the signal as follows:
¼" mono input to Output 1.
¼" stereo input to Output 1 (Tip) & Output 2 (sleeve). (Either of these inputs can be patched to the DI Input if required)
XLR input to XLR Output, the StroboRack SR-EX features high quality *THAT Corporation's* OutSmart™ balanced line receivers and drivers for optimal sound quality. (Note: With the SR-EX Expander installed, the **front** panel mono input is sent to Outputs 1 only).

DI INPUT JACK

This can be used to patch Output 1 or 2 to the built-in active DI, or alternatively as a completely independent DI for a separate instrument.

GROUND SWITCH

This switch controls the *signal ground* (NOT the electrical ground). The DI circuit features a switch, which allows the choice of Ground connected/Auto/Ground lifted. Factory default position is AUTO, this means that the StroboRack detects whether or not there is already a ground present and switches automatically. The StroboRack is one of the first audio products to feature auto-ground, but as other manufacturers incorporate it in the future, remember that in a system with multiple rack units featuring Auto-ground, only one can be the master, otherwise, constant switching will occur, therefore disable Auto-Ground in all but one rack unit.

REMOTE FOOTSWITCH OPERATION (Dual footswitch 403087)

Use a Peterson dual latching footswitch pedal (Part# 403087) inserted into the Preset/Mute jack on the rear panel to remotely 1) advance the StroboRack's presets and 2) mute the StroboRack's output signal for silent tuning.
Use a second Peterson dual footswitch pedal (Part# 403087) inserted into the Output Select jack on the rear panel to remotely activate and deactivate each of the Expander's dual mono outputs.
Remote dual footswitch pedal 403087 is available from your Peterson dealer or from www.petersontuners.com.



Channel Select
Dual Footswitch
Input

Preset/Mute
Dual Footswitch
Input

Tips To Keep Your Instrument In Tune

1	Wash your hands before playing
2	Allow the instrument to reach room temperature before tuning
3	Always tune <i>up</i> to the target pitch, never down
4	Keep the instrument at a constant temperature while playing
5	Check your tuning frequently
6	Wipe down your instrument with a cloth after playing
7	Change strings as frequently as your budget allows
8	If changing string type/gauge, re-intonate/ regulate the instrument
9	On fretted instruments, check for fret wear
10	Clean your instrument regularly and thoroughly
11	On stringed instruments, keep bearing edges lubricated
12	On wind instruments, keep keys/ valves lubricated, check pads.

Tuning Guitars

Peterson tuners are the most sensitive and accurate tuners in the world. They differ completely from digital/needle tuners, so you need to interact differently with them.

Brush the string lightly with the flesh of your thumb; the StoboRack™ requires very little signal to perform optimally. Pluck the string once, not repeatedly.

The StoboRack's superior sensitivity means that the image of the string's signal appears IMMEDIATELY (without the time-lag common in digital tuners) and remains on the display longer. Always tune in the playing position, even when setting intonation.

If you're a 12 string guitar player, you can choose to use EQU to tune all 12 strings or assign a separate sweetener to both the standard and octave strings.

Tuning Pedal Steel Guitars

Peterson tuners are the first and only tuners to contain specific tempered tunings for pedal steel similar to the settings popularized by Jeff Newman.

Generally speaking, these tunings should be executed with both A & B pedals depressed unless the guitar has minimal cabinet drop.

These presets are chromatic and are designed to cover both open strings, pedals and levers.

SE9 is a non-Equal temperament in which the E notes are 9.8 cents sharp

0E9 is a non-Equal temperament in which the E notes are at 00.0 cents

SC6 is a non-Equal temperament for steel guitars using the C6th tuning.

U12 is a non-Equal temperament for steel guitars using E9/B6 tuning.

Tuning Lap Steel Guitars

Many specially tempered lap steel tunings are available on our forum & website www.peterson tuners.com .

Tuning Dobro®* or Resonator Guitars

The StoboRack contains the first and only presets with pure and half tempered third tunings for resonator guitars. The following tunings are possible using either of the two presets:

Open A (A-C#-E-A-C#-E)

Open D (D-A-D-F#-A-D)

Open G (G-B-D-G-B-D)

Remember to tune with your instrument in the playing position.

* Dobro® is a registered trademark of the Gibson Guitar Corporation.

Tuning Violin, Viola or Cello

The StoboRack™ contains the first and only preset pure fifths for violin, viola and cello. Tune using the bow, as plucking the strings does not allow for string deflection due to the weight of the bow.

For quick tuning in adverse conditions, plug a Peterson TP pickup into the StoboRack and attach the pickup to the instrument to be tuned.

Tuning "Early Music" instruments

The StoboRack's long list of classical temperaments can be put to good use for instruments such as harpsichord, lute, and viola da gamba. Remember to change the concert pitch to suit the relevant instrument or period of music. Common Early Music concert pitch is A=415Hz, but 392Hz and 430Hz are also widely used. The StoboRack's concert pitch reference is adjustable in 0.5Hz increments from 390Hz all the way to 490Hz. The Meantones (1/4 & 1/6) are widely used for these instruments.

Tuning Brass & Woodwind Instruments

Use the StoboRack's built-in microphone to pick up the instrument's sound. In noisy environments, attach the TP tuning pickup to your instrument's lead pipe or bell and plug the other end into the tuner. Try a few locations on the instrument to get the best results.

Tuning Bagpipes

For Great Highland Bagpipes, set the base note & root to A, change the Concert A reference to 476Hz (or whatever the Pipe Major's standard is) and select the Just Major preset (JMA). Attach the Peterson TP pickup to the drones and then to the chanter to tune.

For Uilleann, Border, Welsh & Biniou Pipes, set the base note to A, the root to D, change the Concert A reference to 440Hz and select the Just Major preset. Attach the TP tuning pickup first to the drones and then to the chanter to tune.

Tuning acoustic instruments in general

Unamplified acoustic instruments can be tuned using the StoboRack's built-in mic or alternately the Peterson TP clip-on tuning pickup, which senses the instrument's vibration.

An external microphone with a 1/4" plug can also be used.

Instruments tuned to an unknown or fixed Concert A setting.

Play a note on the instrument that is central relative to the complete range of notes playable. While the note is sounding, adjust the StoboRack's Concert A Hz value until the Strobe image stops moving.

The StoboRack is now correctly calibrated to the instrument in question and can be used to tune other instruments so that they are also in tune with this instrument.

StroboRack™ Signal Routing

1: Instrument – StroboRack - 1 Amp (Example: Electric Guitar/Bass/Steel)

Notes:

Input Signal: **Input A or B (A overrides B)** - Mono (TS unbalanced)*

Output Signal: Mono

Footswitch (or Mute button) mutes signal for silent tuning

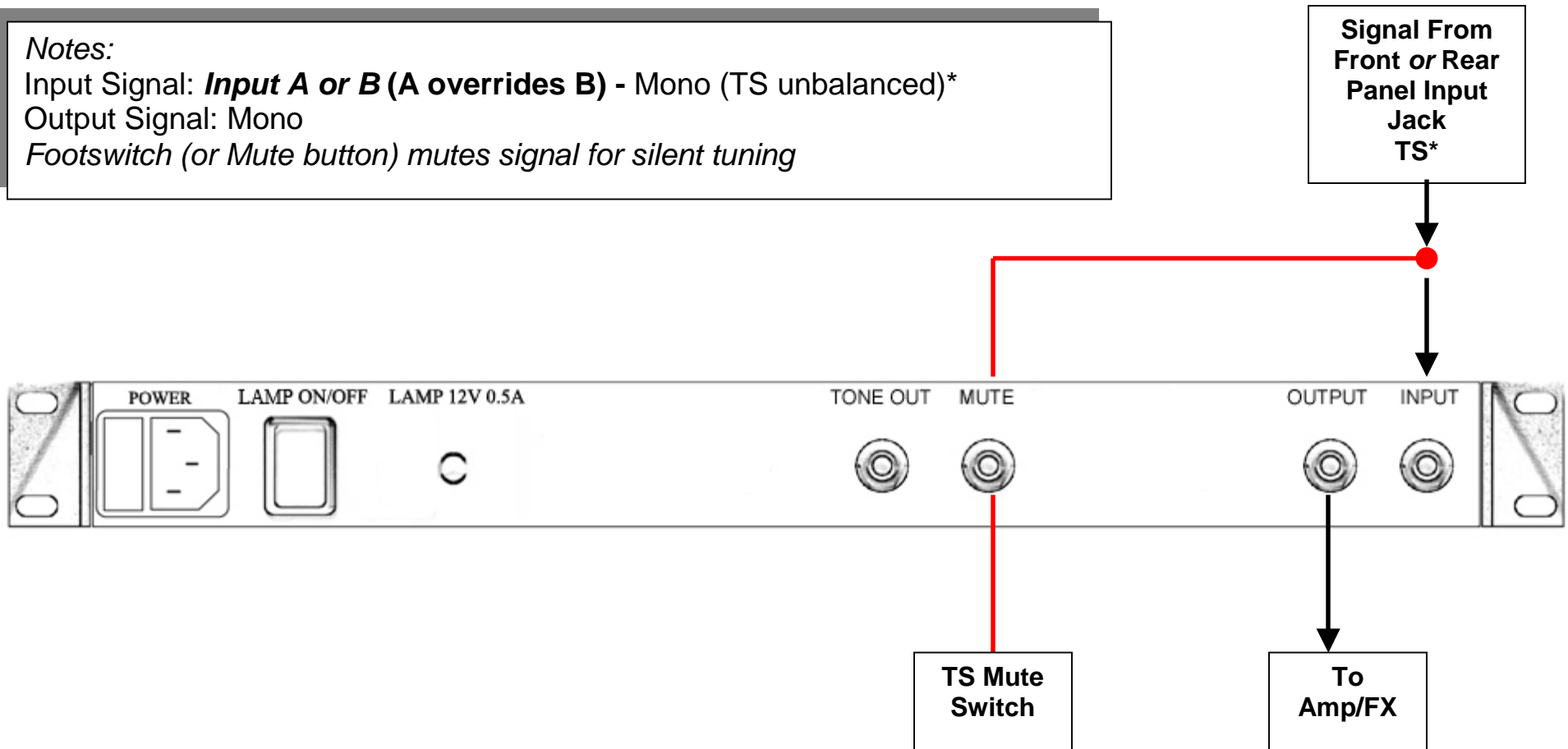

*Input: Standard cable with mono (TS) ¼" plug



StroboRack™ Signal Routing with Optional SR-EX Expander

1: Instrument – StroboRack - 1 Amp (Example: Electric Guitar/Bass/Steel)

Notes:

Input Signal: **Input A or B** (A overrides B) Mono (TS unbalanced)*

Output Signal: Mono

Dual Footswitch mutes output for silent tuning and remotely controls presets.

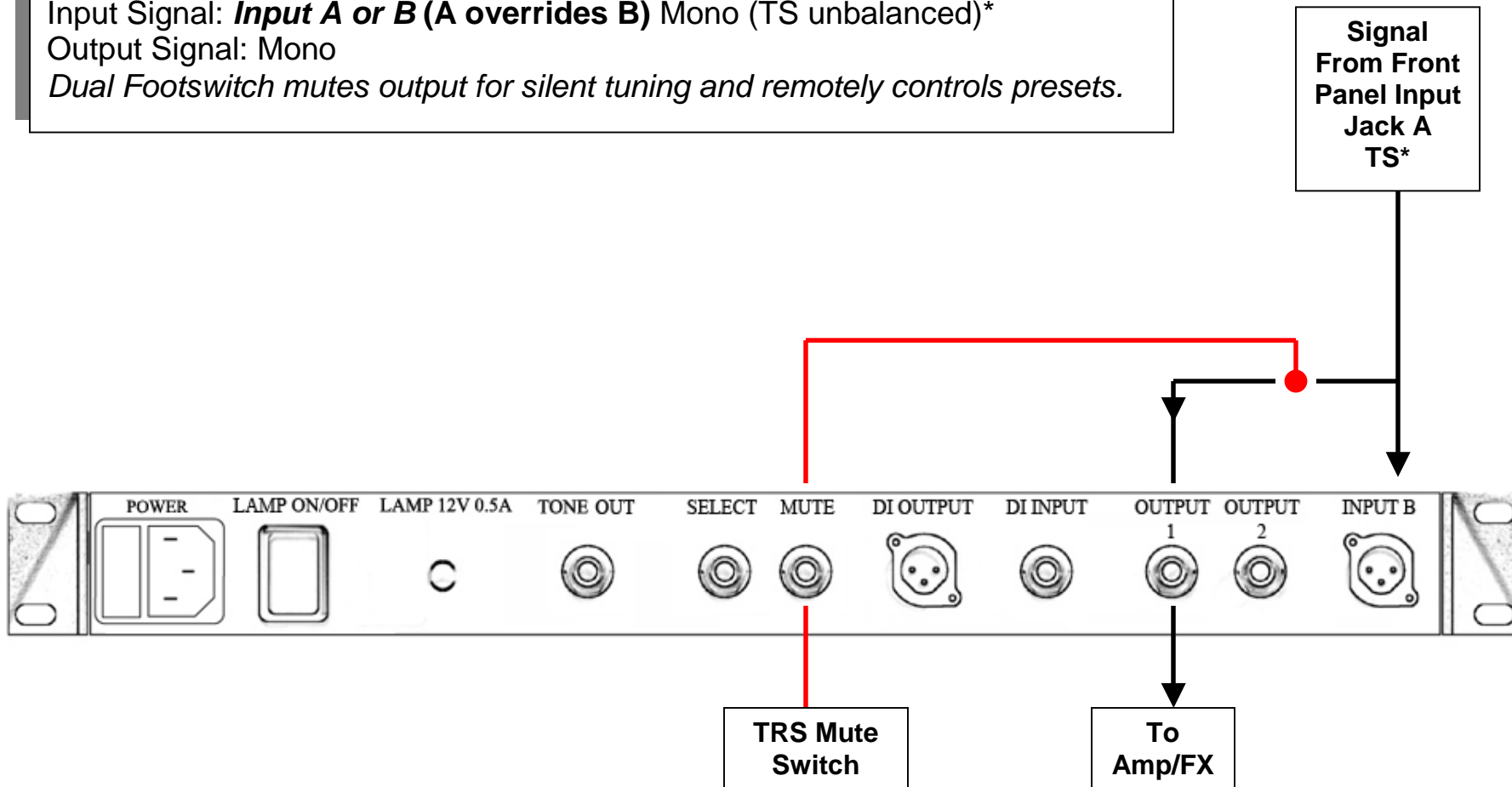

*Input: Standard cable with mono (TS) ¼" plug



2: Instrument - StrobeRack™ - 2 Amps (Example: Electric Guitar/Bass/Steel)

Notes:

Input Signal: *Input B only* Mono signal on bridged ¼ TRS plug*

Output Signals: 2 Mono

Dual Footswitch - 1. mutes all outputs for silent tuning 2. Remotely controls presets.

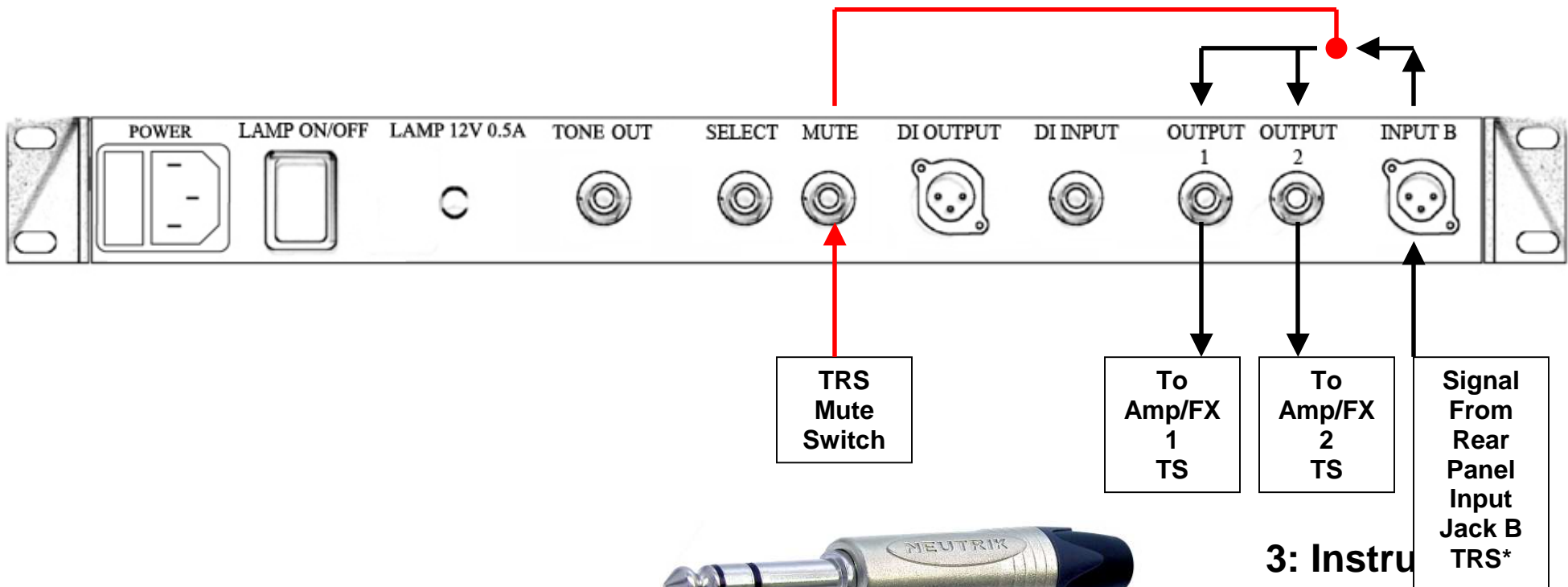

*Input: Mono cable bridged to stereo ¼" plug

3: Instru

StroboRack™ - 2 Amps Switchable (Example: Electric Guitar)

Notes:

Input Signal: *Input B only* - Mono to bridged ¼" TRS plug*

Output Signals: 2 Mono

Dual Footswitch selects output channels

Second Dual footswitch mutes all outputs for silent tuning and remotely controls presets.

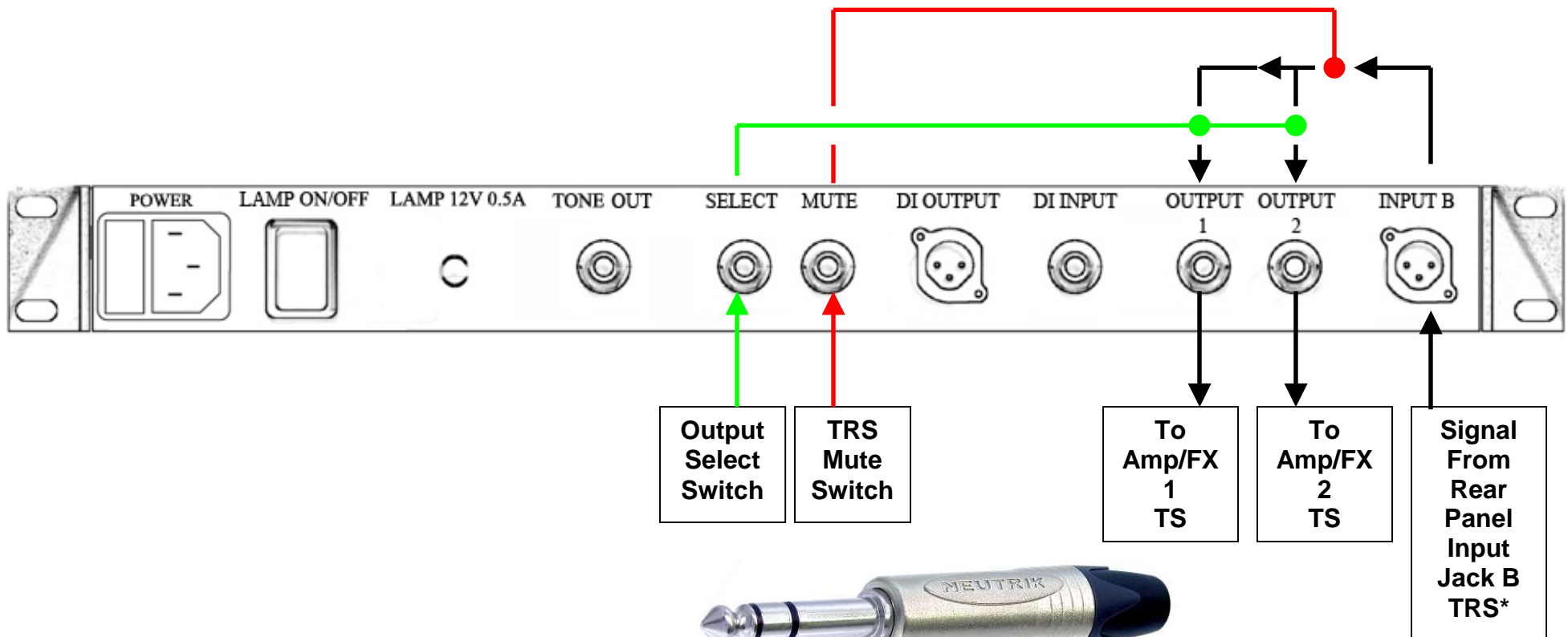

*Input: Mono cable bridged to stereo ¼" plug

4: Instrument – StrobeRack™ - Amp – PA (Example: Electric Bass)

Notes:

Input Signal: *Input A or B (A overrides B) Mono (TS)**

Output Signals: 1 Mono (TS unbalanced), 1 Balanced (XLR)

Footswitch/Mute Button mutes output 1 and DI output for silent tuning

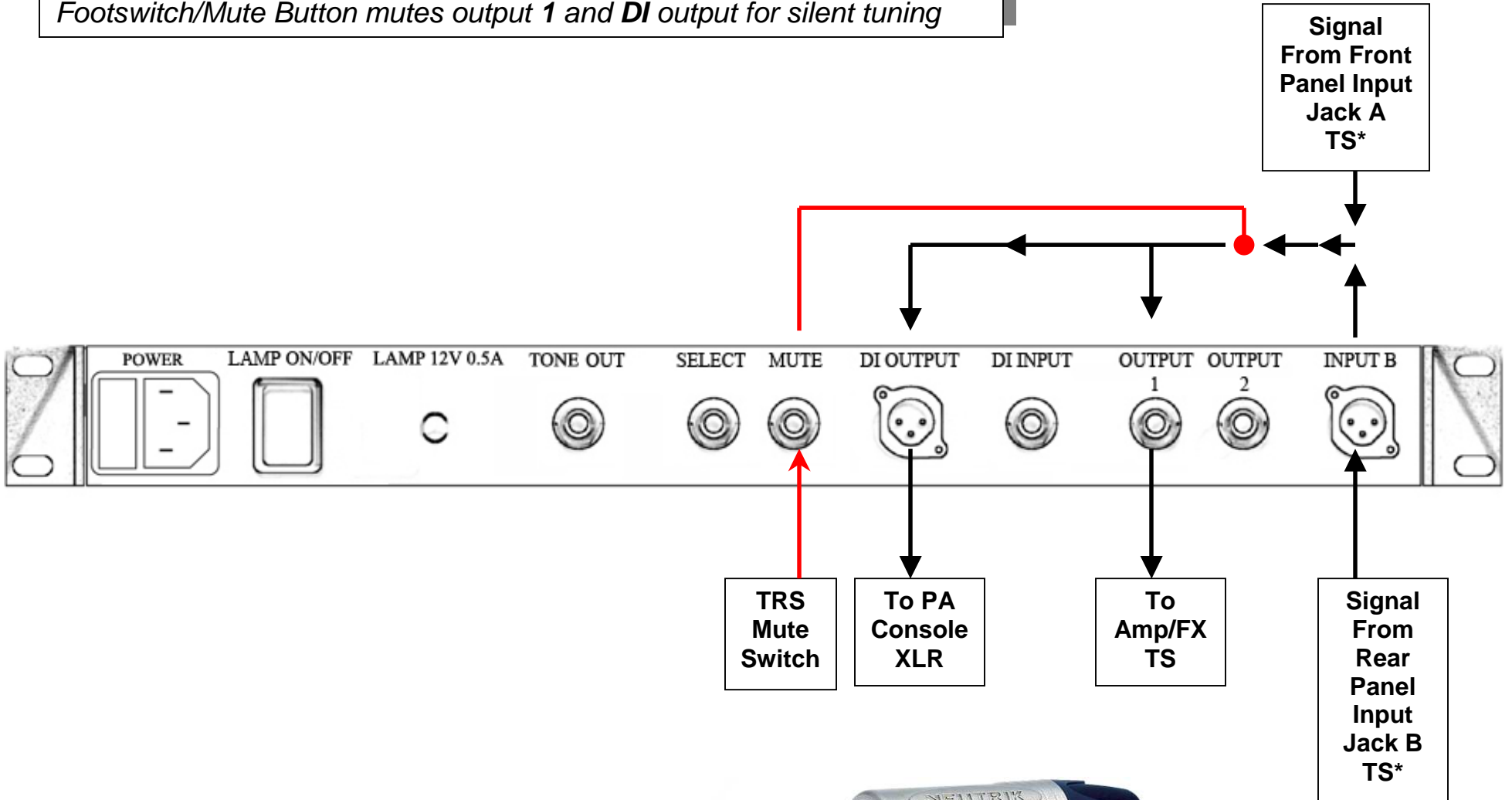

*Input: Standard cable with mono (TS) ¼" plug



5: Instrument - StoboRack™ - PA (Example: Electro-Acoustic Guitar)

Notes:
Input Signal: Input A or B (A overrides B) Mono (TS)*
Output Signals: 1 Balanced (XLR), 1 Mono
Dual Footswitch mutes all outputs for silent tuning and remotely controls presets

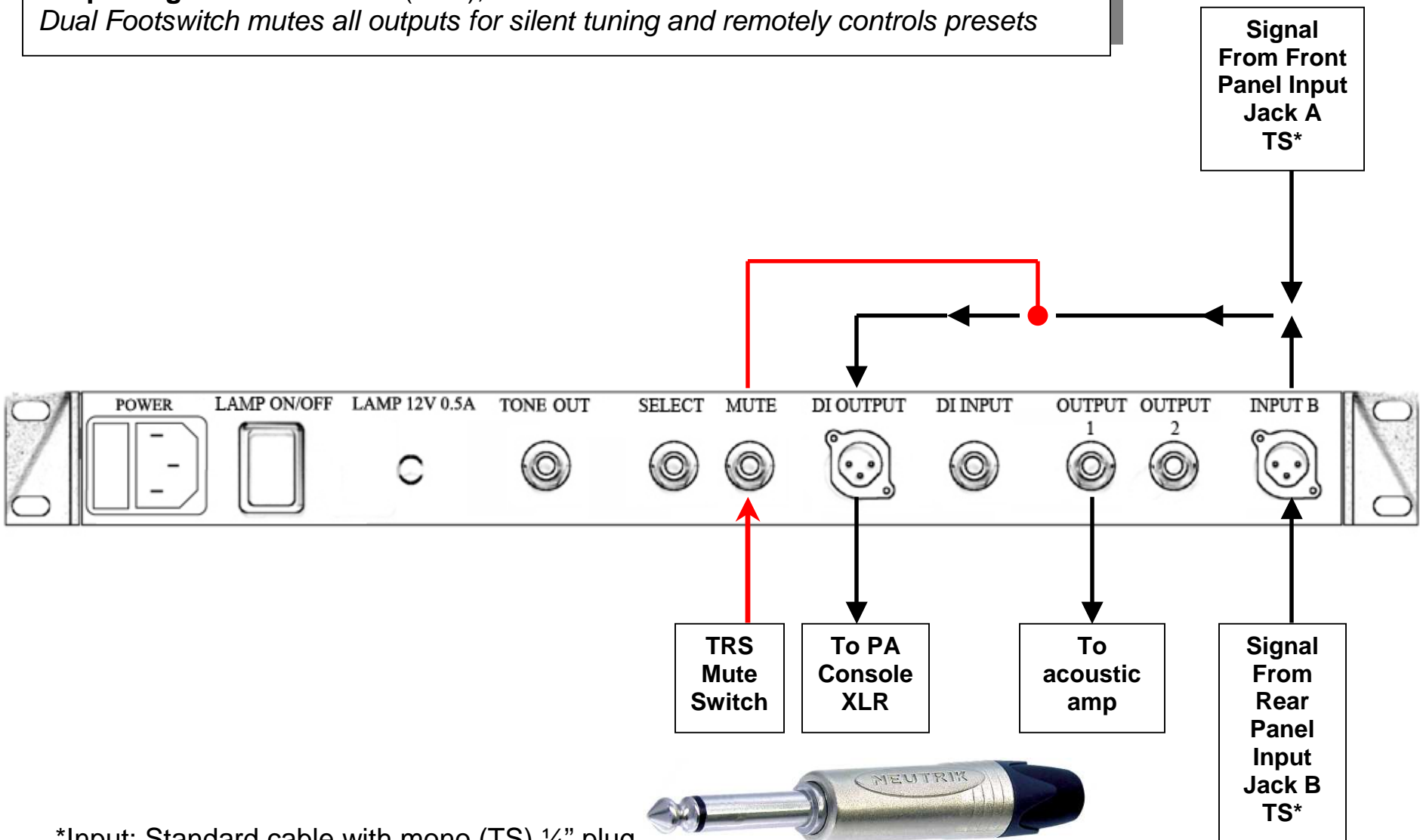

*Input: Standard cable with mono (TS) 1/4" plug

6: Instrument - StrobeRack- 2 Amps – PA (Example: Electric Bass)

Notes:

Input Signal: *Input B only* - Mono to bridged TRS jack plug*

Output Signals: 1 Mono (TS unbalanced), 1 Balanced (XLR)

Dual Footswitch mutes all outputs for silent tuning and remotely controls presets

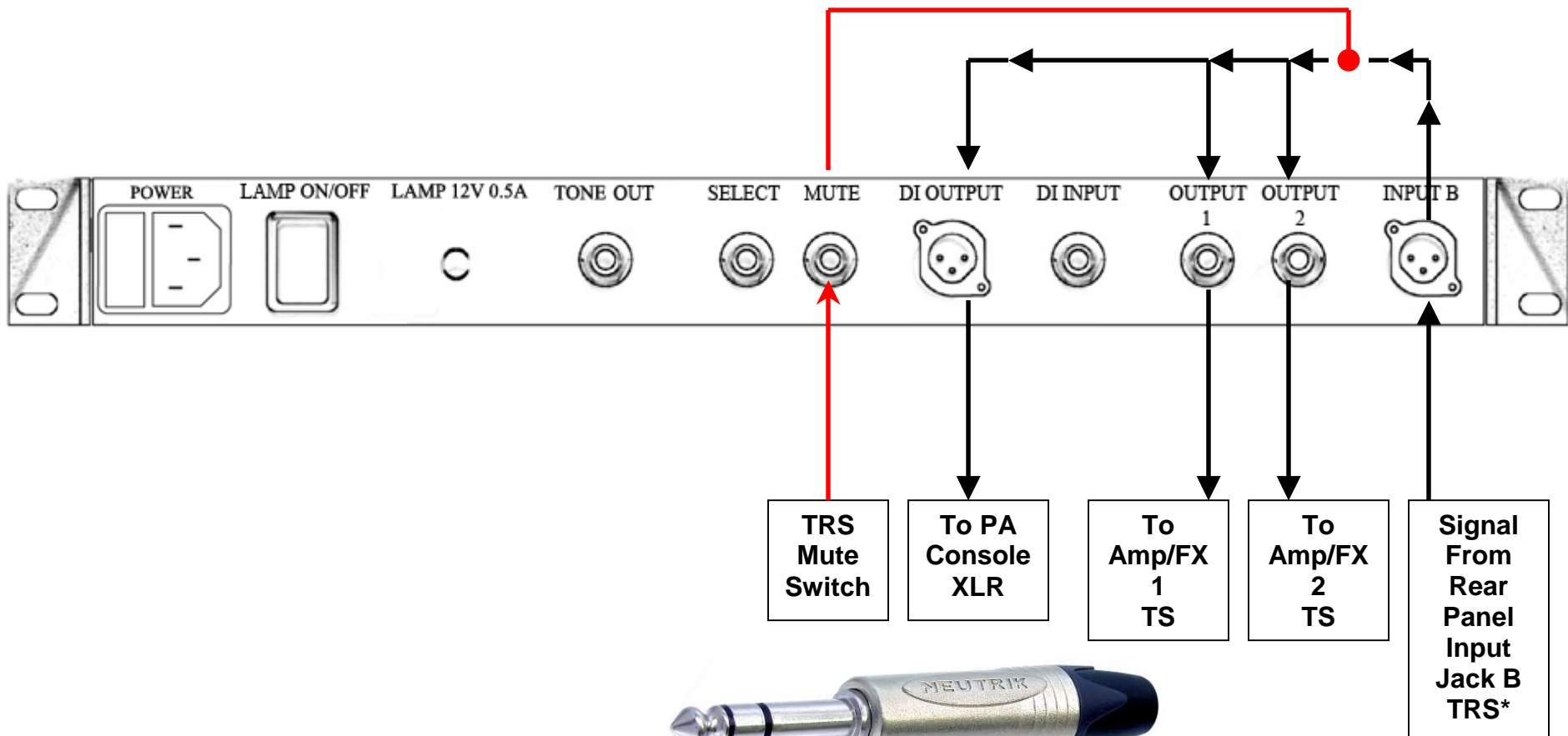

*Input: Mono cable bridged to stereo ¼" plug

7: Stereo Instrument - StrobeRack™ - 1 Amp – PA (Example: Hybrid Guitar/Bass)

Notes:
Input Signal: Input B only - Stereo (TRS Unbalanced)* Tip to output 1, Ring to output 2
Output Signals: 2 Mono (TS unbalanced), 1 Balanced (XLR)
The two input signals are kept separate throughout the tuner.
Dual footswitch: 1. Mutes all outputs and 2. Allows remote control of presets.
Second dual footswitch selects outputs 1 & 2
User can patch **Output 2** to **DI** externally using a **patch cord** to **DI Input**, this automatically disengages Output 1's internal connection to the DI.

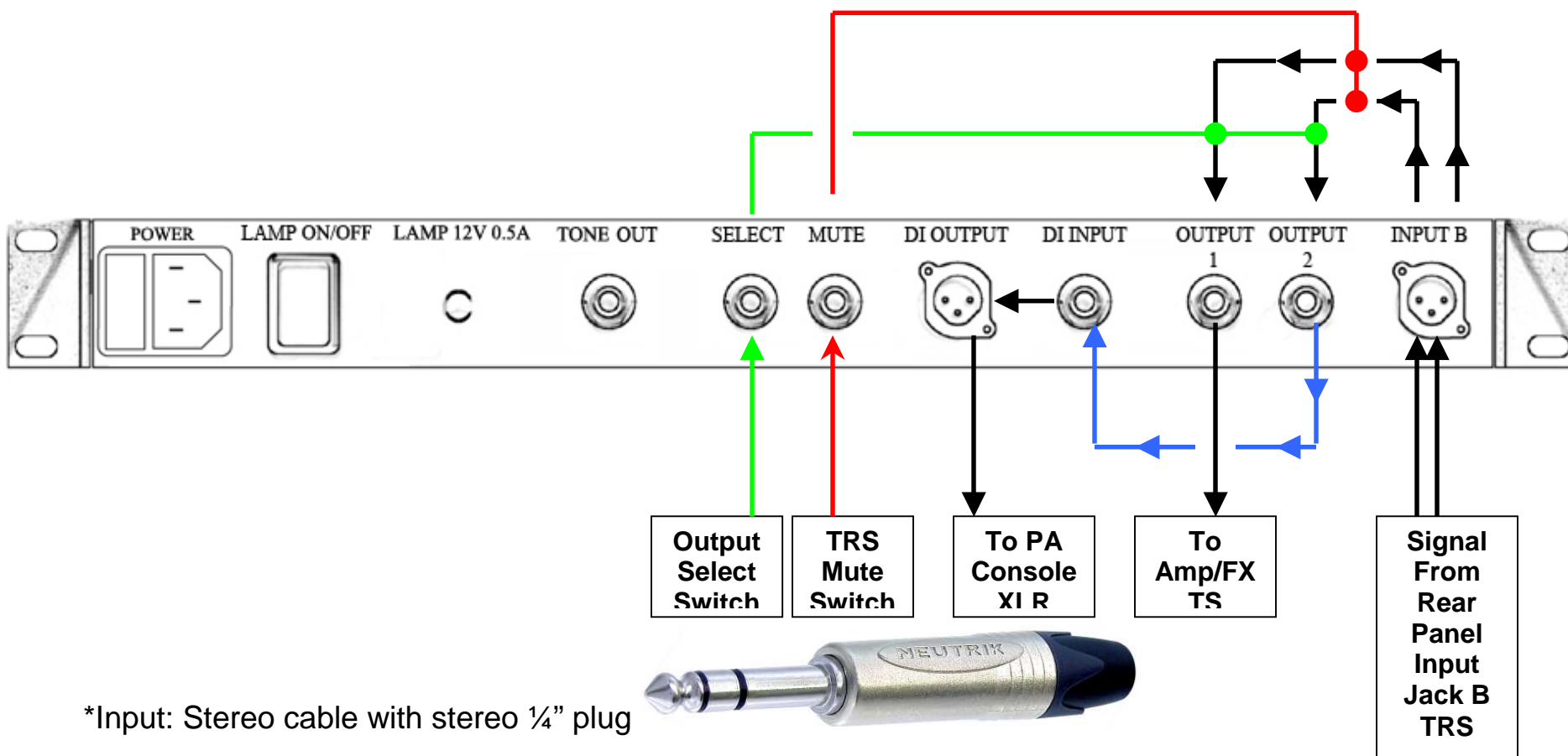

*Input: Stereo cable with stereo 1/4" plug

8: Dual Mono Instrument - StrobeRack- 2 Amps - (Ex: Stick/Tap/Touch Instr.)

Notes:

Input Signals: *Input B only* - 2 Mono (TRS Unbalanced)* Tip to output 1, Ring to output 2

Output Signals: ¼" Mono unbalanced x 2, XLR balanced

The two input signals are kept separate throughout the tuner.

TRS Footswitch mutes all outputs and allows remote control of presets.

Second dual footswitch selects outputs 1 & 2.

If required, connect **Output 2** to **DI** externally using a **patch cord** (see **Example 7**).

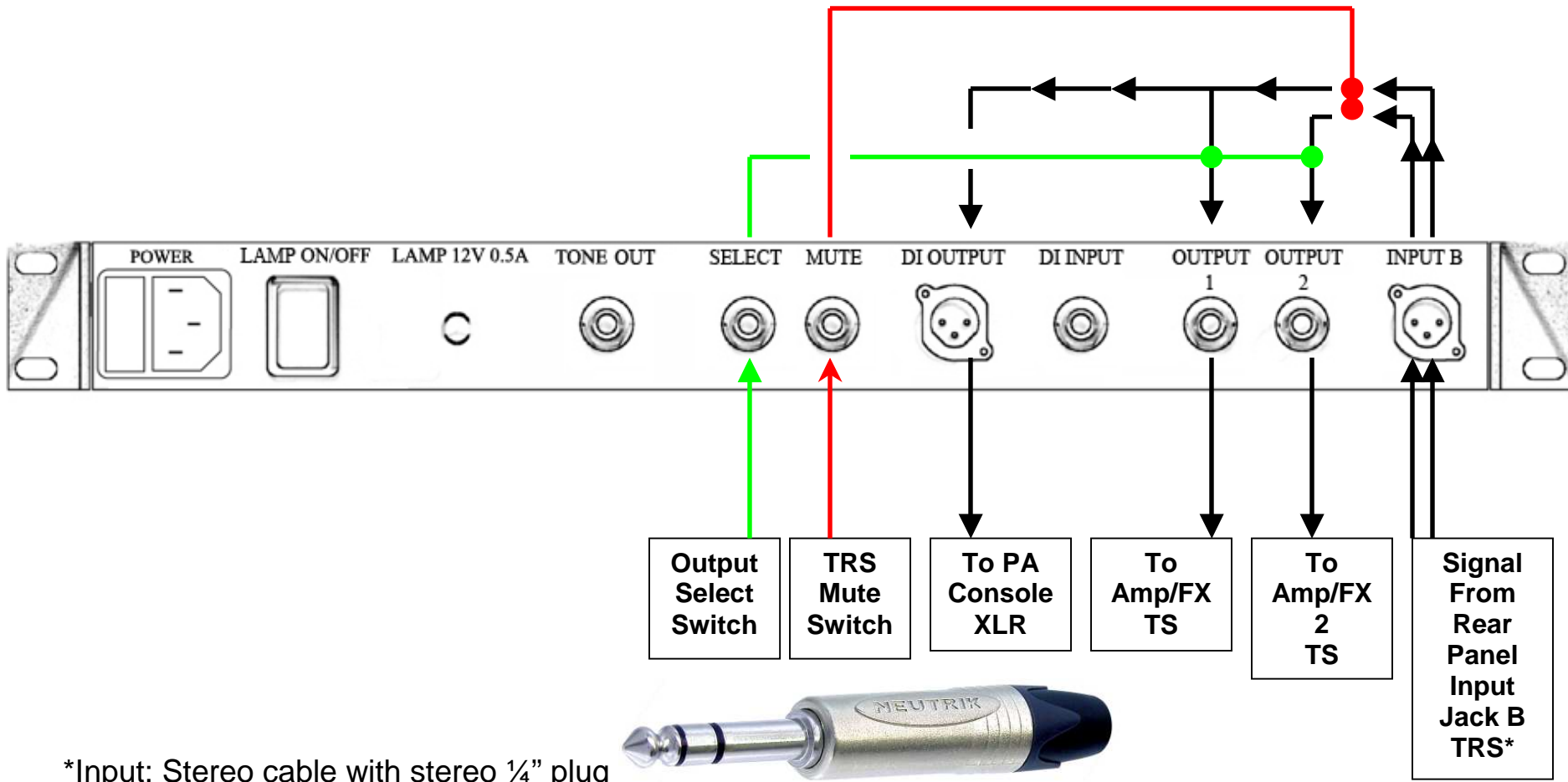

*Input: Stereo cable with stereo ¼" plug

Microphone/Balanced Instrument - StrobeRack™ – PA (Example: Studio)

Notes:

Input Signal: **Input B only** Balanced XLR*

Output Signal: Balanced

DI circuitry is disabled automatically as the signal is already balanced.

Footswitch or mute button mutes balanced output for silent tuning.

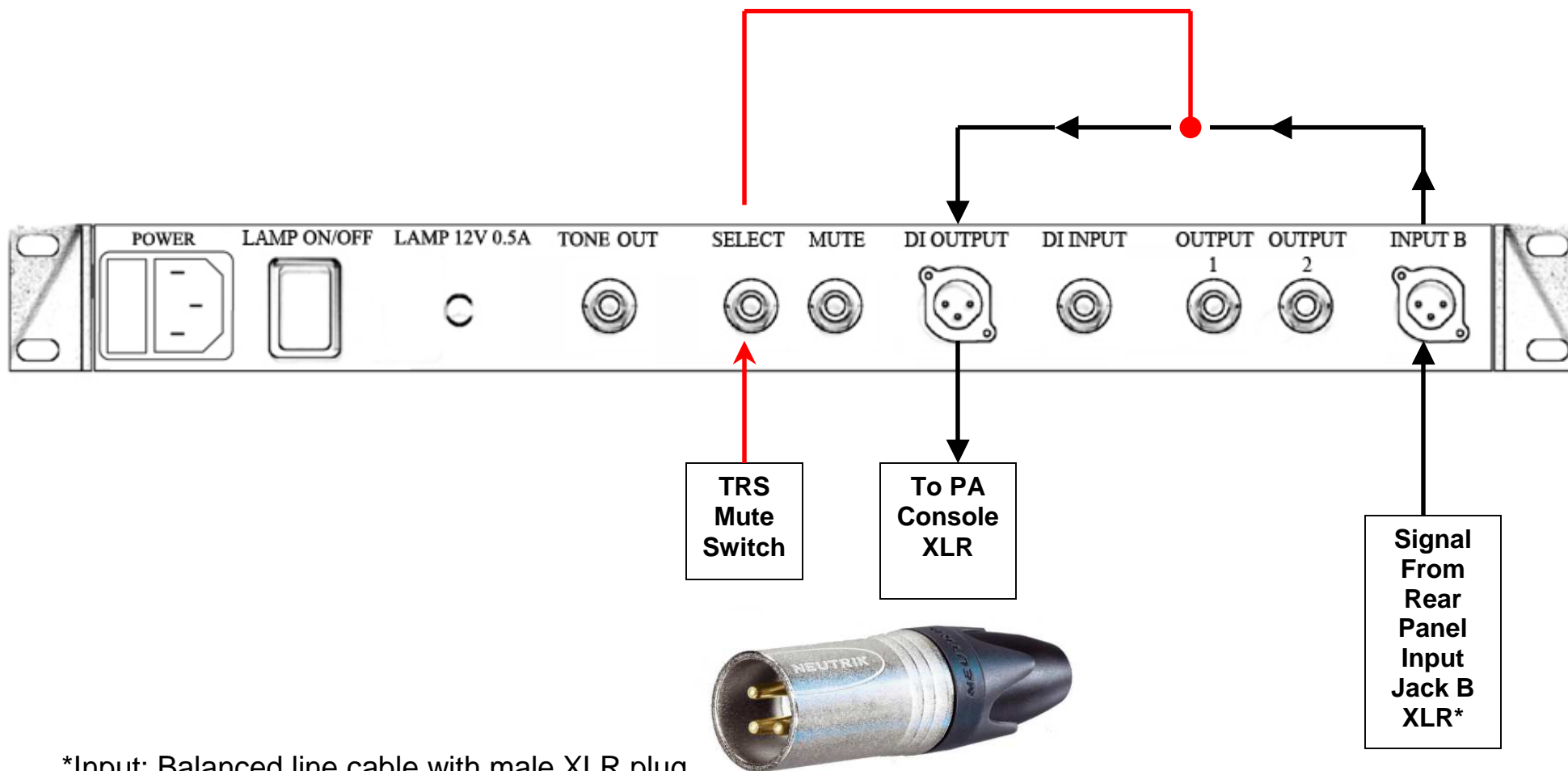

*Input: Balanced line cable with male XLR plug

Frequently Asked Questions

Q. I'm a guitar player who tunes to low C (4 half steps down). Can I still use the Sweeteners™ (like GTR)?

A. Yes. Select GTR and use the DROP control at -4.

Q. I play a 5-String violin, does the VLN preset allow for that?

A. Yes, low C is pre-programmed to be a perfect fifth below G.

Q. I play pedal steel guitar, how do I get the tuner to always power up with the E9 Sweetener active?

A. Choose either S-E9 or 0-E9 and assign that sweetener to a preset.

Q. What Sweetener should I use when I set the intonation on my guitar?

A. It is recommended that Equal temperament be used for setting intonation. After the intonation has been set, choose a Sweetener to tune the guitar.

Q. Why are there only two Dobro^R/Resonator Sweeteners for three tunings and what is the difference between them?

A. Each Sweetener contains the relevant altered thirds for all three tunings. All other notes are unaffected, so you don't need to adjust the tuner even if you switch from open G to open D.

The difference between the two Sweeteners is that in DBO, all thirds are pure but in the other setting, they are half-tempered.

Q. How do I use this tuner to tune piano?

A. You can use StroboRack to tune the temperament octave (C4 to C5)

However, aside from electric pianos like the Wurlitzer or Rhodes pianos, full piano stretch tuning functionality is available only on the Peterson AutoStrobe™ 490ST.

Q. Will the StroboRack hold its memory when I unplug it?

A. Yes, the StroboRack requires no "battery back-up" to hold its memory indefinitely.

Q. Can the StroboRack™ be used for Tap-tuning?

A. You can try, but we generally recommend our true mechanical spinning disc strobe tuners for this application. They are traditionally the most favored tuners for tap-tuning.

Q. Sometimes I see an arrow beside the note E on the display, what does it mean?

A. The arrow denotes the "High" E on a guitar.

Q. I'm tuning my guitar and I can't seem to get the strobe image to stop moving.

A. If you're someone who has never used a strobe tuner before, here are a few tips:

1.) As you may have figured out, the display scrolls to the right when the string is sharp, and to the left when it is flat.

2.) The individual vertical bands represent different octave ranges. There are 3, and ideally you will focus on making the lowest band stand still, although you will notice the others slow to a stop as well.

3.) It is best to not use a pick. Use the fleshy side of your thumb and gently pluck the string.

4.) Unlike needle and LED tuners, you do not need to pluck the string repeatedly. You can generally pluck the string once every 5-7 seconds or until you can no longer hear the sustain of the note.

5.) Sometimes it helps to turn the guitar's volume pot down to about 1/4 to 1/2 of its full potential. Not much signal is required to get a very accurate reading.

6.) Make very slight adjustments to your tuning pegs until the strobe display stops moving. There will be random shifts every once in awhile; this is normal. The tuner is hearing everything that your pickups are giving it... noises and all. When you have the display standing still, or extremely close to standing still, you are within 1/10th of a cent.

Remember, this tuner is about 30 times more accurate than other tuners, so your adjustments need to be that much more precise.

Warranty

We warrant this product to be free of defects in materials or workmanship for a period of one year after delivery to the original purchaser. Our obligation under this warranty is limited to the replacement or repair of any part or parts which prove upon our examination to be defective.

This warranty does not apply to damage resulting from transportation, misuse, abuse, or alteration. The complete unit must be returned to our factory, transportation charges prepaid. In order to speed the return of the unit to you, it is recommended that for all repairs, other than those required as a result of shipping damage, you deal directly with our factory. In case of damage in shipment, a claim should be filed with the carrier. Be sure to include a brief description of the difficulty you are experiencing and your return address.

The above warranty is contingent upon registration within 10 days of the date of receipt of the product by the original purchaser. The warranty conveys specific legal rights to the purchaser, other rights vary from state to state and internationally.

Warranty registration is online at <http://www.petersontuners.com/support/register/index.cfm>

VS-R STROBORACK SPECIFICATIONS

- Manufacturer: Peterson Electro-Musical Products, Inc.
- Phone/Fax +1 708-388-3311 / 708-388-3341
- Website: www.PetersonTuners.com
- E-Mail: info@PetersonTuners.com
- Accuracy: 0.1 cent or within 1/1000th of one semitone (1/10th of one cent) over the entire range.
- Range: 16Hz to 3.6KHz .
- Sensitivity: ± 1mV to 5V.
- Power: 95~250VAC
- Temperaments 11 Classic temperaments.
- Sweeteners: 24 Sweeteners, (+ 8 user programmable).
- Concert A range: 390Hz to 490Hz (adjustable in 0.5Hz increments).
- Features: Exclusive Virtual Strobe Technology™ - Real-Time Operation.
- Weight: 6.66 lbs. / 3.02 kg.
- Dimensions: 19" x 1 3/4" x 8" (48.2cm x 4.5cm x 20.3cm).

Note: Specifications and features subject to change without notice



© 2007 Peterson Electro-Musical Products, Inc.
All rights reserved R1

*“StroboRack“, “Virtual Strobe“, “Sweeteners“, “Sweetened Tunings” and the linear & concentric strobe patterns are trademarks/registered trademarks of:
Peterson Electro-Musical Products, Inc. U.S. Patent # 6,580,024*

